

ISTRUZIONI DI MONTAGGIO INSTALLATION BOOK

Serie UM/UI

UM



UI



U: Installation, use, maintenance manual

READ CAREFULLY THIS MANUAL BEFORE THE INSTALLATION OF THE
APPLIANCE

IDENTIFICATION OF THE APPLIANCE

Every unit is identified with a label that is inside the unit on the electric control side. The label shows the manufacturer's data and the unit type

RECEIVING THE APPLIANCE

Check every unit before accepting it. Be sure the packaging is not damaged or bended or broken. In case of a damaged package, open it immediately and check the contents before accepting it; check the chassis and the panels of the fan coil, the heat exchanging coil, the condensate drain pan, the filters, the proper fan rotation, all the eventual accessories. Do not refuse the shipping: please write all the damages on the shipping document and take pictures of the damages



GENERAL WARNINGS

This manual is part of the unit and must always be with the appliance. After removing the appliance from the packaging, be sure that there are no damages and the appliance corresponds to your order. In case of great damage : write a description of the damages on the carrier's copy of the shipping documents, take pictures of the damages, send immediately a letter to the carrier, and send a copy to your dealer and/or to the manufacturer, specifying model and serial number.

GENERAL INDICATIONS

An electric connection 230V single-phase and an hydraulic connection to the water chiller/boiler are necessary to allow proper working of the appliance. The unit have been designed for installation in rooms where people live, and for heating and/or cooling of such rooms; the unit must be used only for that purpose. Each unit is checked and tested in the factory, and is delivered to the customer only if properly working. All repair/maintenance operation must be carried out by qualified specialists. Failure to observe the rules contained in this manual, or any unauthorized modification / tamper of the appliance can cause dangerous situations and will immediately invalidate the warranty of the appliance. The manufacturer is not responsible in case of damages caused by:

- Unauthorized changes or modifications to the appliance,**
- Improper installation or improper use.**

MANDATORY SAFETY RULES DURING INSTALLATION

The fan coil must not be installed: outdoor, in a too humid environment, in explosive or corrosive environment, in a very dusty environment. A bipolar safety switch must be installed, to disconnect the appliance from the electric power supply; the switch must: be properly sized, be easily accessible and close to the appliance, have a minimum 3 mm distance between its contacts. The appliance must be properly connected to an electric earth.

- Do not place flammable / dusty goods close to the appliance.
- Do not remove the labels from the inside of the appliance

MANDATORY SAFETY RULES DURING USE, MAINTENANCE, REPAIR

It is dangerous: to touch the fan coil with wet parts of the body and bare feet; to modify or tamper the settings of the safety devices; to spray water or flammable liquids/gas onto the fan coil; to introduce foreign objects or the hands through the air intake and discharge grills; to introduce foreign objects or the hands into the fans. Do not bend, pull, detach the electric wires out-coming the fan coil, even if it is disconnected from the power supply.

Before any maintenance / repair:

- disconnect electrical power source and secure in disconnected position;**
- close the water valves;**
- wait until the water is at the.**

Before any maintenance be sure that: the unit is disconnected from the electric power source; the water valves are closed; the water temperature is not dangerous (too hot or too cold).same temperature of the room wear safety gloves. In case of replacement of components, use only spare parts supplied by the manufacturer. If the fan coil is installed in very cold climates, and a long un-operative period is forecasted, the hydraulic circuit must be

completely emptied, in order to avoid risk of ice inside the tubes; ice will cause big damages. If a damper for external air is installed, the cold air can cause ice inside the tubes of the coil, and ice will break the tubes. If necessary, some glycol must be mixed with the water of the hydraulic circuit. The coils are tested up to 3000 kPa (30 bar). In case the air filter has to be cleaned or changed be sure it is fitted again in the appliance before re-starting the unit.

OPERATING LIMITS

Electric power supply: V230/1/50Hz ±6% - Minimum temperature of the cooling water (without glycol): 5°C
 Maximum temperature of the heating fluid: 120°C - Maximum allowed operating pressure: 14,4 bar

ETHYLENE GLYCOL

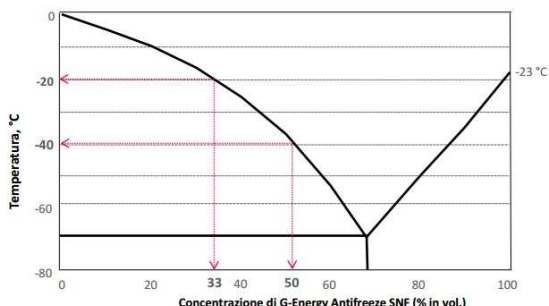

La diluizione al 50% fornisce protezione dal gelo fino a -40°C, al 33% fino a -20°C. La diluizione al 68% fornisce la massima protezione dal gelo (-69°C), diluizioni maggiori del 70% in acqua non sono consigliabili.

In case of installations where the temperature can drop below 0°C, it is necessary to add glycol to the water according the table. Ethylene glycol is used to protect the circuit from freezing, and to prevent the tubes to be broken. The following table gives the percentage of glycol to add in order to obtain a specific freezing temperature. The mix of water and glycol has a specific mass and viscosity which varies depending on the temperature and concentration; consequently this affects the capacity of the fan coil. Glycol is generally used as an inhibitor of corrosion, so it is necessary to measure its concentration at least once a year

In weight	In volume	Temperature	Specific mass Kg/dm ³		Specific heat KJ/kgK		Increase 0 → 100°C
			50°C	100°C	50°C	100°C	
0 %	0 %	0 °C	0,9888	0,958	4,18	4,20	4,33 %
10	9,6	- 4	1,000	0,970	4,10	4,12	5,00
20	19,4	- 10	1,012	0,980	3,95	4,05	5,40
30	27,4	- 17	1,025	0,991	3,81	3,92	5,60
34	33,4	- 21	1,030	0,994	3,73	3,86	5,85
40	39,6	- 25	1,037	1,000	3,60	3,78	6,20
44	43,7	- 30	1,041	1,004	3,00	3,73	6,32
50	49,5	- 37	1,047	1,010	3,45	3,65	6,50
52 % max	51,6	- 40	1,050	1,012	3,42	3,62	6,51

WASTE DISPOSAL Packaging, consumables, replaced parts must be disposed according to the local safety laws and environmental protection laws.

TECHNICAL CHARACTERISTICS OF THE FAN MOTOR MINIMUM CROSS SECTION OF THE ELECTRIC SUPPLY WIRES

Size	U	02	03	04	06
Motor absorption	A _{in}	56	69	88	131
Motor Power	W _{in}	0,21	0,31	0,38	0,57
Minimum cable section	mm ²	1,5	1,5	1,5	1,5

Data shown in the following tables are valid only for the fan motor and do not include any accessory, i.e. valves or electric heaters.

- The cross sections of the wires that are shown in the following tables are: the minimum required to connect the fan coil to the electric supply, valid for wires maximum 10 m long, valid for a maximum current load 5 A/mm², valid only for the fan motor and DO NOT include any accessory (valves, electric heaters, pumps, controls, etc.), valid only for copper wires.
- The voltage drop between operating and non-operating unit must remain below 3%; if the voltage drop is greater than 3%, a bigger wire is required.
- Minimum cross section of the wires 1.5 mm².

ELECTRIC HEATERS V230/1/50-60Hz

Tube INOX AISI 304L – Fins Fe/AlZn -Rules DPR 547/55 – CENELEC EN60 - IEC 335.1 - CEI 61-50

Each power element	W (±5%)	700	1000	1200	1500	2000	2500
Active length	L mm	350	350	550	750	750	950
Current absorbed	A	3,1	4,5	5,5	6,6	9,0	11,0
Thermic charge	W/cm ²	4,3	6,0	4,4	4,0	5,3	5,1

MECHANICAL INSTALLATION

Choose an area that can allow a proper circulation of the air, both incoming to and out-coming from the fan coil. Do not place any curtain or any object that can obstruct the unit air outlet and return. Adequate clearances around the fan coil are necessary to allow easy access for maintenance and cleaning operations. The fan coil must be mounted level, to assure proper operation and drainage. Level the fan coil by adjusting the supporting feet or the hanging rods; level the unit by checking on the unit casing. Do not use the coil or drain pan for leveling, as they are pitched to provide proper drainage. Use shock absorbers supports, to avoid transmission of noise and vibrations thru the walls. Put shock absorbers between the unit and the air ducts (both return and supply sides), to avoid transmission of noise and vibrations through the ducts. Don not install the fan coil where water dripping inside the appliance may happen. Before installation, be sure that electrical and hydraulic connections are on opposite sides of the appliance.

HYDRAULIC CONNECTIONS

Proper hydraulic connections and proper circulation of the water inside the circuit assure: good operation and long life of the appliance, limited energy consumption. The piping must be: properly sized (proper diameter); properly insulated, to avoid condensate dripping and heat dissipation. In general, the water inlet is in the lower part of the coil; the water outlet is in the upper part of the coil. When valves and/or stop valves are mounted, due to space constraints it may be necessary to put the water inlet in the upper side and the water outlet is in the lower side of the coil. Allowed materials for the condensate drain piping are: PVC or steel. In any case, after the piping has been connected to the unit, tape sealant must be used to prevent water leakages.

BEFORE INSTALLING THE FAN COIL, READ CAREFULLY THE WARNINGS AND THE SAFETY RULES BE SURE THE WATER INSIDE THE CIRCUIT IS: FILTERED, FREE FROM SCALE OR IRON OXIDES, THAT CAN DAMAGE THE HEAT EXCHANGING COIL AND THE VALVES IF NECESSARY, WATER MUST BE TREATED WITH CHEMICAL AGENTS, IN ORDER TO PREVENT: CREATION OF SCALE, CORROSION, GROWTH OF ALGAE, CREATION OF SLUDGE. TO CONNECT THE HEAT EXCHANGING COIL TO THE WATER CIRCUIT: ALWAYS USE TWO SPANNERS; BE CAREFUL AND AVOID ANY DAMAGE TO THE COPPER TUBES OF THE COIL. ALWAYS FIT TWO GATE VALVES ON THE WATER CIRCUIT: ONE VALVE ON THE WATER INLET OF THE FAN COIL, AND ONE VALVE ON THE WATER OUTLET. THE MOTORIZED WATER VALVES REQUIRE PROPER SPACE TO BE REMOVED AND MUST NOT BE MOUNTED UPSIDE DOWN. CONDENSATE DRAIN PIPING : CREATE A DRAIN TRAP; CREATE A MINIMUM SLOPE 50 mm/m; DO NOT CREATE COUNTERSLOPES; DO NOT FLATTEN OR KINK THE PIPE; CHECK THE CONNECTION. BY POURING WATER INTO THE DRAIN PAN . CHECK THE CIRCUIT : GIVE HYDROSTATIC PRESSURE, AIR VENT THE COIL OF THE UNIT, BE SURE THAT NO DRIPPING OCCURS. DO NOT CHECK THE CIRCUIT JUST BEFORE A HOLIDAY: BIG TROUBLES MAY OCCUR IF QUALIFIED CONTROL PERSONNEL IS NOT ON DUTY.

DRAIN PAN DISCHARGE: GENERAL NOTE

- It is indispensable to install a siphon on the drain line to prevent the fan sucking obnoxious odours or bacteria from the drain system, creating ideal condition inside the airhandling unit for the proliferation of pathogenic germs and micro organisms, also favouring the diffusion of “Legionella Pneumophila” responsible for “Legionnaires’ disease”
- A drain connection without a siphon, or with an incorrectly installed siphon, allows air to be sucked into the unit, the condensate cannot drain and is carried over into the next section of the unit and the condensate will spill out of the unit, flooding the surrounding area, when the fan is shut down.
- The siphon must not be hermetically connected to the drain line to permit air locks to be broken.
- A siphon in positive pressure must never be connected to another in negative pressure.
- The drain line downstream of the siphon must have sufficient slope to carry away the condensate and its’ diameter should be at least the same as the unit drain connection.
- The drain piping can be in various materials: steel, copper, PVC.
- If the drain line is improperly supported it may deform, create air locks and prevent proper drainage of the condensate.
- It is good practice to insulate the siphon and drain line to prevent the formation of condensate on the outside of the piping. In winter antifreeze should be added to the water in the siphon.
- Beware of evaporation of the water in the siphon during shut down periods. The maintenance personnel should ensure that the siphons are always full.
- The siphon should be equipped with an inspection plug in an easily accessed position.
- The condensate drain pan should be cleaned periodically to avoid stagnant condensate, formation of algae, and encrustations.

DRAIN IN POSITIVE PRESSURE

$T = 2 p \quad S = T / 2 \quad H = T - S$

Example

$P = 400Pa = 40 \text{ mmwc}$

$T = 80 \text{ mm} - S = 40 \text{ mm} - H = 40 \text{ mm}$

DRAIN IN NEGATIVE PRESSURE

$T = - 2 p \quad S = T / 2 \quad H = T - S$

Example

$P = - 250Pa = - 25 \text{ mmwc}$

$T = 50 \text{ mm} - S = 25 \text{ mm} - H = 25 \text{ mm}$

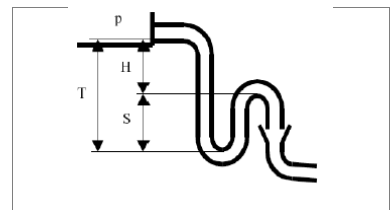

ELECTRICAL CONNECTIONS General rules

BEFORE INSTALLING THE FAN COIL, READ CAREFULLY THE WARNINGS AND THE SAFETY RULES. ELECTRICAL CONNECTIONS MUST BE MADE ONLY BY QUALIFIED PERSONNEL, AND MUST ACCOMPLISH THE LOCAL ELECTRICAL AND SAFETY CODES AND ORDINANCES. A BIPOLAR SAFETY SWITCH MUST BE INSTALLED, TO DISCONNECT THE APPLIANCE FROM THE ELECTRIC POWER SUPPLY; THE SWITCH MUST: BE PROPERLY SIZED, BE EASILY ACCESSIBLE AND CLOSE TO THE APPLIANCE HAVE A MINIMUM 3 MM DISTANCE BETWEEN ITS CONTACTS. ALL ELECTRICAL CONNECTIONS ARE TO BE MADE IN ACCORDANCE WITH LOCAL ELECTRICAL AND SAFETY CODES AND ORDINANCES. THE FAN COIL MUST BE PROPERLY EARTHED; MAKE EARTH CONNECTION PRIOR TO ANY OTHER ELECTRICAL CONNECTION. FOR WIRING AND INSTALLATION, REFER TO THE WIRING DIAGRAM OF THE FAN COIL, THAT ARE FITTED ON EACH UNIT AND SHOWN IN THIS MANUAL. ACCESSORIES THAT ARE NOT DESCRIBED IN THIS MANUAL REQUIRE SEPARATE POWER SUPPLY; ALL POWER SUPPLIES MUST BE PROPERLY PROTECTED WITH SWITCHES AND FUSES.

Be sure the voltage is inside the allowed limits: see "Operating Limits" and "Technical Characteristics". Be sure the electrical circuit upstream the appliance is properly sized to carry the current that is necessary to operate the fan coil (see "Technical Characteristics") and all the other devices already installed or forecasted. Minimum cross section of the wires 1.5 mm². Wires to the auxiliary circuits (switches, controls, interlocks, etc.) must have 1.5 mm² minimum cross section. Choice proper cross section of the wires: current must be limited to 5 A/mm²; voltage drop between not-operating and operating unit must be limited to 3%.

Motor wiring

The fan coil has a terminal block that is mounted on the internal side panel on the opposite side to the hydraulic connections. The terminal block is ready to be connected to the fan speed selector switch or to the thermostats. Both the fan speed selector switch and the thermostats are supplied as accessories, and their connection to the unit is shown in the installation instructions supplied with them. After the wires have been inserted in the terminal block, tighten the screws on each terminal, to assure a good electric contact. Failure to accomplish this requirement may cause serious danger and possibility of fire.

START-UP

INSTALLATION OR AFTER EACH MAINTENANCE, MAKE THE FOLOWING CHECKS BEFORE STARTING THE UNIT

- Water pressure inside operating limits
- Adequate cross section of electrical wires
- Electrical connections completed and tightened
- Power supply voltage inside the operating limits
- Duct connections completed (ducted units only)
- Filter is free of construction debris
- Air return flow is free of obstacles and obstructions
- Air delivery flow is free of obstacles and obstructions
- Fan rotates freely
- Condensate drain pan free of construction debris
- Drain lines clean and operating
- Drain lines with proper slope, without counterslope and restrictions
- Condensate drain water evacuates properly
- Adequate cross section of water pipes
- Piping connections completed
- Air vent completed

FILTER

The function of the air filter is to remove foreign matter such as dirt, soot, pollen, and other impurities from the air passing through it. Said impurities may enter into the fan coil and damage it. The filter should be replaced once a year; the filter should be replaced more frequently if the fan coil is used in a very dirty or dusty environment. Between one replacement and the next one, the filter has to be kept clean. A dirty filter does not filter the air passing through it, and: impairs the operating efficiency of the unit by restricting the air flow over the coil; encourages the growth of bacteria that may be dangerous to the health. To clean the filter, please operate as follows: remove the filter from its operating position, clean the filter using a vacuum cleaner, if the filter is too dirty and it's impossible to clean it, the filter must be replaced with a new one. AFTER CLEANING THE FILTER, PLACE THE FILTER BACK IN ITS OPERATING POSITION

CONDENSATE DRAIN PAN

The condensate drain pan must be checked before the beginning of the cooling season. The condensate drain pan and the discharge hole may clog with scale; remove scale withy proper chemical products. The condensate drain pan may collect dirt that falls from that coil and, in case of vertical installation, may contain foreign materials that fall into the fan coil passing thru the air delivery grill. Dirt and scale that are cumulated in that drain pan may impair the evacuation of condensate water, so causing water coming out from the unit. To clean the condensate drain pan,

operate as follows: remove the drain pan from its operating position, clean the drain pan with fresh water, wipe the drain pan carefully, place the drain pan back in its operating position.

HEAT EXCHANGING COIL

If the air filter is properly cleaned, the coil does not need any maintenance. Use a vacuum cleaner in case that coil need to be cleaned. If the coil is very dirty, brush between fins with a stiff nylon brush. BE VERY CAREFUL, TO AVOID ANY DAMAGE TO THE FINS OF THE COIL IF THE COIL REMAINS DIRTY, OR MAKES A BAD SMELL, ASK A SPECIALIZED TECHNICIAN FOR PROPER CLEANING AND MAINTENANCE

FAN AND FAN MOTOR

MAINTENANCE OF THE FAN AND THE FAN MOTOR MUST BE CARRIED OUT ONLY BY SPECIALLY TRAINED PEOPLE. NO ATTEMPT SHOULD BE MADE TO LUBRICATE THESE PERMANENTLY LUBRICATED MOTORS: THE MOTOR MAY BE CLOGGED BY SLUDGE. At least once a year the following operations must be carried out: remove dust and dirt from the inside of the scroll; be sure the fan is properly fixed to the motor and is well balanced. The fan motors do not require any maintenance, as they are permanently lubricated.

ELECTRICAL CONNECTIONS

At least one a year, be sure the screws of the terminals are well tightened.

The motor does not rotate at all, or does not rotate properly

- No electrical power coming to the fan coil.
- Electrical connections are wrong, are not according to the wiring diagrams.
- The fan speed selector switch (if installed) is in a wrong position.
- The seasonal changeover switch (if installed) is in a wrong position.
- The setting of the thermostat (if installed) is wrong.

The fan coil does not cool / heat properly

- No water coming to the fan coil.
- The filter is dirty / clogged.
- The heat exchanging coil is dirty / clogged.
- There is some air into the water circuit.
- The fan does not rotate at all, or does not rotate properly

Water comes out from the unit

- The heat exchanging coil is broken.
- There are some leakages from the hydraulic connections
- The condensate drain pan is dirty, or the discharge hole is clogged.
- The condensate piping has a wrong slope, or the slope is not enough.
- The condensate piping is clogged.

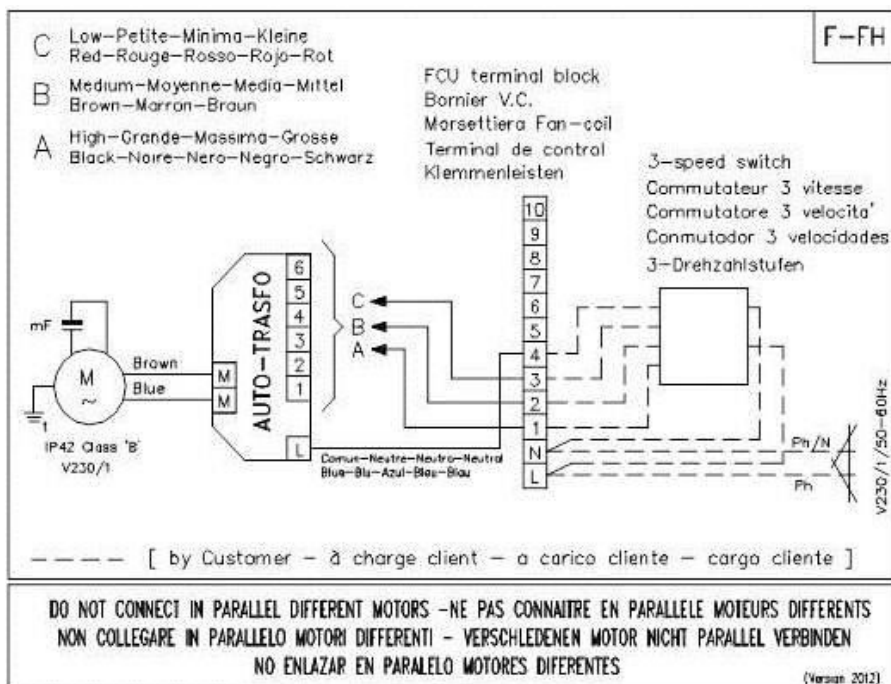

Technical data shown in this booklet are not binding. Manufacturer shall have the right to introduce at any time whatever modifications deemed necessary to the improvement of the product. 01.01.2017

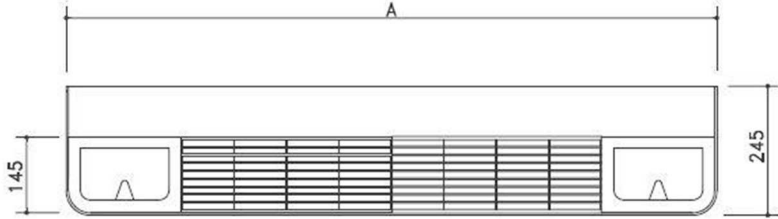
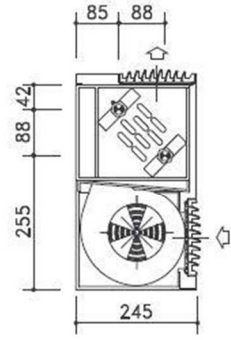
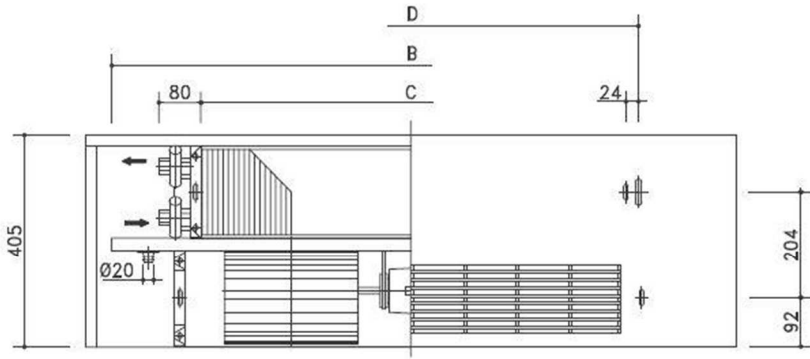

UM	A	B	C	D	Peso
02	840	740	400	468	18
03	1040	940	600	668	23
04-05	1240	1140	800	868	26
06	1440	1340	1000	1068	33

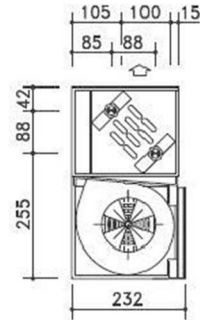
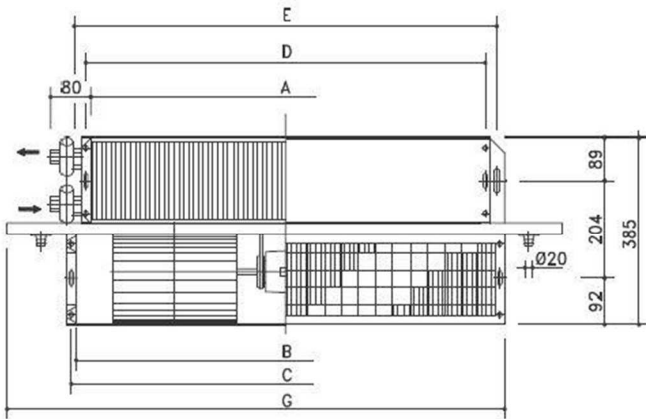

NB: Eliminando sulla banchella uno scarico condensa, destro o sinistro é possibile accorciare il ventilatore (vedere quota G)

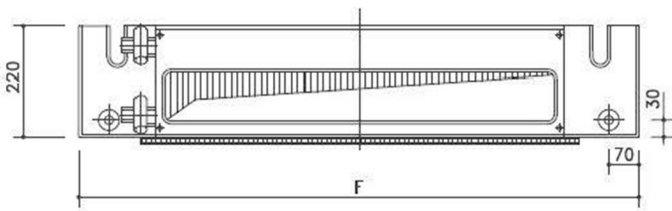

UI	A	B	C	D	E	F	G	Peso
02	400	460	480	420	468	740	620	16
03	600	660	680	620	668	940	820	19
04-05	800	860	880	820	868	1140	1020	24
06	1000	1060	1080	1020	1068	1340	1220	28