



DELFI

KC 12-24-28

KR 12-24-28

KRB 12-24-28



IST 04 C 429 - 01

InSTalla Tlon, uSe and malnTenanCe



CE

BRAND NAME



EN

Translation of the original instructions (in Italian)

Dear Sirs,

thank You for choosing and buying one of our products. Please read these instructions carefully in order to properly install, operate, and maintain the product.



WARNING

- **We inform users that:**
 - **Boilers shall be installed by an authorised company under the requirements set forth by the prevailing rules, in full compliance with the prevailing regulations and standards.**
 - **Anyone entrusting installation to an unqualified installer will be subject to administrative sanctions.**
 - **Boilers must be maintained by qualified personnel only, under the requirements set forth by the prevailing rules.**
-

We hereby inform you that certain models, versions and/or accessories relevant to the products this manual refers to, might not be available in some countries.

Therefore, it is recommended to contact the manufacturer or the importer in order to get the necessary information about the actual availability of such models, versions and/or accessories.

The manufacturer reserves the right to modify the products and/or its components as deemed necessary, in any moment and without prior notice.

This instruction manual is available in two languages, Italian and English, without prejudice to the prevalence of Italian language in case of differences in translation and/or dispute on construction of the text.

General notes for installing and maintenance technicians, and users

This instruction manual is an integral and essential part of the product. It shall be supplied by the installer to the user who shall keep it carefully to consult it whenever necessary.

This document shall be supplied together with the equipment in case the latter is sold or transferred to others.



DANGER

**This equipment has been manufactured to be connected to a room heating system and to a DHW distribution system.
Any other use shall be considered unsuitable and dangerous for people, animals, and/or property.**

The equipment shall be installed in compliance with the prevailing standards and in accordance with the manufacturer's instructions specified in this manual: the manufacturer will not be held responsible for injuries to people and animals and/or damages to property resulting from an incorrect installation.

Damage and/or injury caused by incorrect installation or use and/or damage and/or injury due to non-observance of the manufacturer's instructions shall release the manufacturer from any and all contractual and extra-contractual liability.

Before installing the boiler, check that the technical data correspond to the requirements for its correct use in the system.

Check that the boiler is intact and it has not been damaged during transport and handling. Do not install equipment which is clearly damaged and/or faulty.

Do not obstruct the air intake openings.

Only original accessories or optional kits (including the electric ones) are to be installed.

Properly dispose of the packaging as all the materials can be recycled. The packaging must therefore be sent to specific waste management sites.

After removing the packaging, make sure that its elements (clips, plastic bags, foam polystyrene etc.) are not left within the reach of children as they are potential hazard sources.

In the event of failure and/or faulty functioning, switch off the boiler. Do not attempt to make repairs: contact qualified technicians.

Original parts must be used for all repairs to the boiler.

Non-observance of the above requirements may affect the safety of the boilers and endanger people, animals and/or property.



WARNING

The boiler must be serviced periodically as indicated in the relevant section of this manual.

Appropriate boiler maintenance ensures efficient operation, environment preservation, and safety for people, animals and objects.

Incorrect and irregular maintenance can be a source of danger for people, animals and property.

The user is strongly advised to have the system serviced and repaired by qualified personnel, satisfying all prevailing law requirements, and trained to properly carry out these operations.

In the event of long periods of inactivity of the boiler, disconnect it from the electrical power mains and close the gas cock. **The electronic antifreeze function will not be operative with the device disconnected from the electric power supply and gas cock closed.**

Should there be a risk of freezing, add antifreeze: it is not advisable to drain the system as this may result in damage; use specific anti-freeze products suitable for multi-metal heating systems.



DANGER

With gas fired boilers, take the following measures if you smell gas:

- **Do not turn on or off electric switches and do not turn on electric appliances.**
- **Do not ignite flames and do not smoke.**
- **Close the main gas cock.**
- **Open doors and windows.**
- **Contact a Service Centre, a qualified installer or the gas supply company.**

Never use a flame to locate a gas leak.

The boiler is designed for installation in the countries indicated on the technical data plate: installation in any other country may be a source of danger for people, animals and/or property.

The manufacturer will bear no contractual and tortious liability for failure to comply with all the instructions above.



DANGER

With gas fired boilers, take the following measures if you smell gas:

- **Do not turn on or off electric switches and do not turn on electric appliances.**
- **Do not ignite flames and do not smoke.**
- **Close the main gas cock.**
- **Open doors and windows.**
- **Contact a Service Centre, a qualified installer or the gas supply company.**

Never use a flame to locate a gas leak.

The boiler is designed for installation in the countries indicated on the technical data plate: installation in any other country may be a source of danger for people, animals and/or property.

The manufacturer will bear no contractual and tortious liability for failure to comply with all the instructions above.

1.	<i>Instructions for the user</i>	8
1.1	<i>Control panel</i>	8
1.2	<i>Interpreting boiler status from display indications</i>	10
1.3	<i>Boiler operation</i>	11
1.4	<i>Boiler shut-down</i>	14
1.5	<i>Maintenance</i>	17
1.6	<i>Notes for the user</i>	17
2.	<i>Technical features and dimensions</i>	18
2.1	<i>Technical features</i>	18
2.2	<i>Dimensions</i>	20
2.3	<i>Boiler layouts</i>	23
2.4	<i>Operating data</i>	26
2.5	<i>General characteristics</i>	27
2.6	<i>ERP and Labelling data</i>	30
3.	<i>Instructions for the installer</i>	36
3.1	<i>Installation standards</i>	36
3.2	<i>Choosing where to install the boiler</i>	36
3.3	<i>Positioning the boiler</i>	36
3.4	<i>Installing the boiler</i>	38
3.5	<i>Boiler room ventilation</i>	38
3.6	<i>Air intake and flue gas venting system</i>	39
3.7	<i>Checking combustion efficiency</i>	45
3.8	<i>Connection to gas mains</i>	46
3.9	<i>Hydraulic connections</i>	46
3.10	<i>Connection to electrical mains</i>	48
3.11	<i>Connection to ambient thermostat (optional)</i>	48
3.12	<i>Installation and operation with Open Therm Remote Control (optional)</i>	48
3.13	<i>TSP parameters</i>	51
3.14	<i>Filling the system</i>	55
3.15	<i>Starting up the boiler</i>	56
3.16	<i>Available head</i>	56
3.17	<i>Wiring diagrams</i>	58
3.18	<i>Adaptation to other gas types and burner adjustment</i>	62
4.	<i>Testing the boiler</i>	65
4.1	<i>Preliminary checks</i>	65
4.2	<i>Switching on and switching off</i>	65
5.	<i>Maintenance</i>	66
5.1	<i>Maintenance schedule</i>	66
5.2	<i>Combustion analysis</i>	66
6.	<i>Decommissioning, disassembly and disposal</i>	67
7.	<i>Malfunctions, possible causes and solutions</i>	68
7.1	<i>Troubleshooting</i>	68

Fig. 1 Control panel	8
Fig. 2 Filler cock	15
Fig. 3 Model KC dimensions	20
Fig. 4 Model KR dimensions	21
Fig. 5 Model KRB dimensions	22
Fig. 6 Model KR wiring diagram	23
Fig. 7 Model KC wiring diagram	24
Fig. 8 Model KRB wiring diagram	25
Fig. 9 Paper template	37
Fig. 10 Installation examples	40
Fig. 11 Type C13 - C33 coaxial ducts	42
Fig. 12 Type C12 - C33 coaxial pipes dimensione	43
Fig. 13 Split pipe kit 0KITSDDP00	44
Fig. 14 Dimensions for split pipes	44
Fig. 15 Plugs position	45
Fig. 16 Hole position	45
Fig. 17 Connection to gas mains	46
Fig. 18 Condensate drain	47
Fig. 19 Thermoregulation curves	50
Fig. 20 Available head KC-KR-KRB 12	57
Fig. 21 Available head KC-KR-KRB 24	57
Fig. 22 Available head KC-KR-KRB 28	57
Fig. 23 Wiring diagram KC	58
Fig. 24 Wiring diagram KR	59
Fig. 25 Wiring diagram KRB	60
Fig. 26 Intake pipe	62
Fig. 27 Mixer	62
Fig. 28 Mixer plastic body	63
Fig. 29 Assembling direction	63
Fig. 30 Adjusting CO2 value	64

Tab. 1 KC 12 adjustment data26
Tab. 2 KC 24 adjustment data26
Tab. 3 KC 28 adjustment data26
Tab. 4 Model KC general data27
Tab. 5 Model KR/KRB general data.....	.28
Tab. 6 KC-KR-KRB 12 combustion data.....	.29
Tab. 7 KC-KR-KRB 24 combustion data.....	.29
Tab. 8 KC-KR-KRB 28 combustion data.....	.29
Tab. 9 ERP and Labelling data - KC 12.....	.30
Tab. 10 ERP and Labelling data - KC 24.....	.31
Tab. 11 ERP and Labelling data - KC 28.....	.32
Tab. 12 ERP and Labelling data - KR/KRB 12.....	.33
Tab. 13 ERP and Labelling data - KR/KRB 24.....	.34
Tab. 14 ERP and Labelling data - KR/KRB 28.....	.35
Tab. 15 Boiler re-ignition temperature.....	.49
Tab. 16 Limits to be set for TSP parameters and default values in relation to boiler type (TSP0) - I.....	.51
Tab. 17 Limits to be set for TSP parameters and default values in relation to boiler type (TSP0) - II.....	.52
Tab. 18 Limits to be set for TSP parameters and default values in relation to boiler type (TSP0) - III.....	.53
Tab. 19 Limits to be set for TSP parameters and default values in relation to boiler type (TSP0) - IV.....	.54
Tab. 20 Relationship between "Temperature and Nominal resistance" for temperature probes.....	.61
Tab. 21 P0-TSP0 parameter values.....	.63
Tab. 22 Flue CO2 content64
Tab. 23 Diameter of nozzles - diaphragms (mm)64

1. Instructions for the user

1.1 Control panel

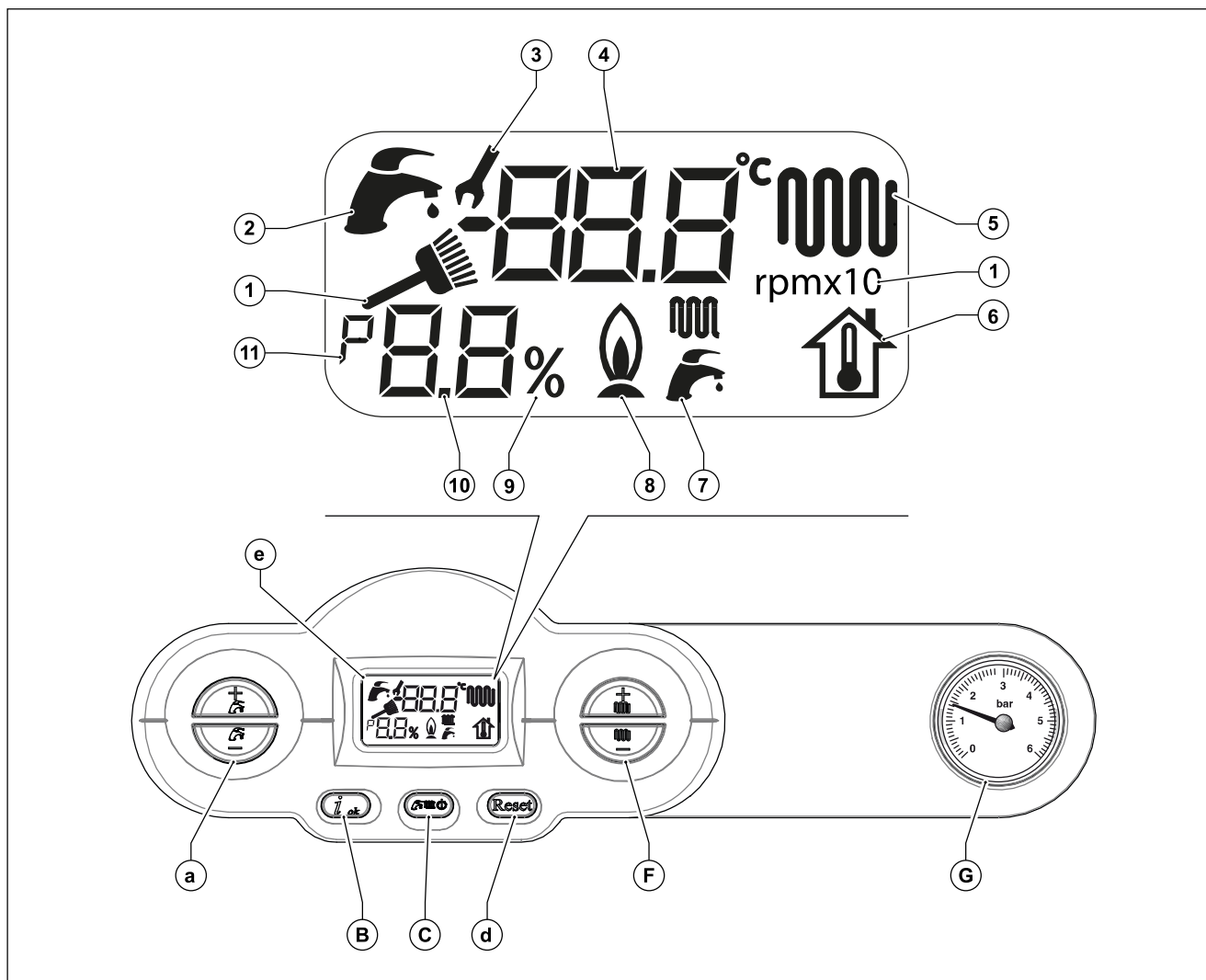













Fig. 1 Control panel

- A. DHW setting (+/- DHW).
- B. Parameter confirmation and information request.
- C. Operating status selection.
- D. Alarm reset and back to the starting page during parameter selection.
- E. LCD display.
- F. CH water temperature (+/- CH) and parameter settings.
- G. Heating system water pressure gauge.

Ref.	Symbol	Steady on	Flashing
1	 rpmx10	Visualization of chimney sweep and "rpmx10" (fan rounds number) indication.	Indicates that you are accessing the flue cleaning function.
2		A DHW request is present	Displaying of the DHW temperature set-point
3		During parameter editing, the wrench symbol stays on until the set datum is confirmed.	Not used
4		Indication of the temperatures and values of fault and shutdown parameters	Not used
5		A heating request is present	Displaying of the heating temperature set-point
6		Not used	Displaying of the fictitious ambient temperature set-point
7	 	Symbols showing instant DHW production, CH. Symbol on = function enabled. Symbol off = function disabled.	Not used
8		Lit flame indication	Not used
9		Percentage indication	Not used
10		Displaying of the number of parameters, or of the system pressure, or of the burner power percentage	Not used
11		Indication of "parameter" inside the parameter menu	Not used

1.2 Interpreting boiler status from display indications

1.2.1 Normal operation

Boiler in STANDBY mode



Boiler in SUMMER mode
No active function
Flow temperature displayed

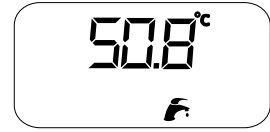

Boiler in WINTER mode
No active function
Flow temperature displayed

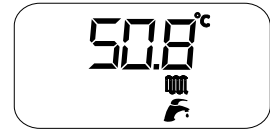

Boiler in CENTRAL HEATING ONLY mode
No active function
Flow temperature displayed



Boiler in SUMMER mode
Domestic hot water withdrawal
DHW temperature displayed

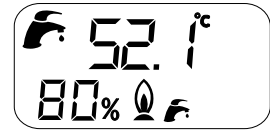

Boiler in WINTER mode
Domestic hot water withdrawal
DHW temperature displayed

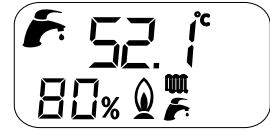

Boiler in WINTER mode
CH function active
Flow temperature displayed

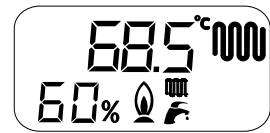

Boiler in CENTRAL HEATING ONLY mode
CH function active
Flow temperature displayed

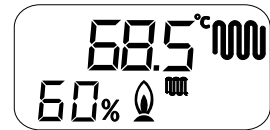

1.2.2 Malfunction

To identify any malfunctions, refer to paragraph *Troubleshooting* on page 68.

1.3 Boiler operation

1.3.1 Switching on



DANGER

It is presumed that the boiler has been installed by a qualified installer, it has been commissioned and is ready to operate correctly.

- Open the gas shut-off cock.
- Turn the master switch installed ahead of the boiler to ON.
- The display turns on and indicates the function currently active (see *Interpreting boiler status from display indications* on page 10).
- Select the boiler operating mode: OFF/SUMMER/WINTER/CH ONLY (see button (C) in Fig. 1 Control panel on page 8).
- Set desired CH temperature (see *CH function* on page 11).
- Set desired DHW temperature (see *DHW function* on page 12).
- Set the desired room temperature on the ambient thermostat inside the home (if installed).



WARNING

After a prolonged period with the boiler not in use, and with LPG fired boilers in particular, some starting difficulty may be encountered.

Before starting the boiler switch on another gas powered device (e.g. kitchen range).

Beware that even by following this procedure, the boiler might still experience some starting difficulties and shut down once or twice. Press the "RESET" button to restore boiler operation.

1.3.2 Selecting the operating mode

To select the boiler operation mode press **C** Operating mode selection.

Whenever button is pressed, the following modes are enabled in sequence: "SUMMER", "WINTER", "CH ONLY", "OFF".

"SUMMER" operating status

When the "SUMMER" mode is enabled, only the DHW production function is active.

"WINTER" operating status

When the "WINTER" mode is enabled, both DHW and CH functions are active.

"CH ONLY" operating status

When the "CH ONLY" mode is enabled, only the heating water production function is active.

"OFF" operating status

When the "OFF" mode is enabled, no function is active.

1.3.3 CH function

To set the heating water temperature, press +/- **CH** buttons.

Heating temperature adjustment range depends on the selected operating range.:

- standard range: from 20°C to 78°C (pressing **CH +/-**);
- reduced range: from 20°C to 45°C (pressing **CH +/-**).

Operation range selection is to be implemented by an installer or a qualified Service Centre (see par. *Selecting the operating range in heating mode* on page 49).

During temperature setting, the  symbol flashes on the screen and the CH current temperature setting is displayed.

When the CH system requests heat from the boiler, the LCD displays the CH symbol  and the current CH flow water temperature.

The waiting time between one boiler ignition and the following one, used to prevent boiler frequent turning on and off, ranges between 0 and 10 minutes (default value: 4 minutes), and can be edited with the **P11** parameter.

Should water temperature in the system fall below set minimum value, between 20°C and 78°C (default value 40°C for standard range, 20°C for reduced range) to be edited with the **P27** parameter, the waiting time is reset and the boiler re-ignites.

The burner ON symbol  shows while the burner is operating.

1.3.4 DHW function

DHW production function is enabled on model KC and on KR/KRB models with external water heater (optional).

DHW production function is enabled in one of the following operating modes: SUMMER or WINTER.

Such function has always priority over CH water supply.

To set the domestic hot water temperature, press **DHW +/-** buttons.

During temperature setting, the  symbol flashes on the screen and the DHW current temperature setting is displayed.

Model KC

For KC model, DHW temperature may be set within a range from +35 °C to +57 °C.



WARNING

A flow limiter is installed within the boiler, which limits DHW output flow rate.

This limit is: 10 litres per minute for model KC 12; 13 litres per minute for model KC 24 and 14 litres per minute for model KC 28.

Models KR/KRB

On KR/KRB models with external water heater (optional) and water heater temperature probe (optional, supplied by the manufacturer; included in the standard supply for KRB model), temperature range is between 35 °C and 65 °C.

On KR/KRB models with external water heater (optional) and water heater probe (optional, supplied by the manufacturer), every 15 days the anti-legionella function will be enabled, consisting in raising the water heater temperature to 65°C for 30 minutes independent of other settings.

1.3.5 Freeze protection function

This boiler is fitted with a freeze protection system, which works when the following functions are activated: OFF/SUMMER/WINTER/CH ONLY.



DANGER

The freeze protection function only protects the boiler, not the whole heating system.

The central heating system can be effectively protected against icing by using specific anti-freeze products that are suitable for multi-metal systems.



WARNING

Do not use anti-freeze products for car engines, and check the effectiveness of the product used over time.

In case burner cannot be ignited due to the lack of gas, the freeze protection functions are anyway enabled through the circulation pumps.

1.3.5.1 Flow freeze protection function

When the heating water temperature sensor detects a water temperature of +5 °C, the boiler switches on and stays on at its minimum heat output until the temperature reaches +30 °C or 15 minutes have elapsed.

The pump continues to operate even if the boiler shuts down.

1.3.5.2 Plate heat exchanger freeze protection (only model KC)

When the DHW temperature sensor detects a water temperature of +5°C, the boiler switches on and stays on at its minimum heat output until the DHW temperature reaches +10°C or 15 minutes have elapsed (the deviating valve is in the DHW position).

During the DHW freeze protection operation the temperature detected by the flow probe is constantly checked, and in case it reaches +60 °C the burner is switched off.

The burner is switched on again if the operation request in anti-freeze mode is still present and the flow temperature is below +60°C.

The pump continues to operate even if the boiler shuts down.

1.3.5.3 Water heater freeze protection function (for models KB/KRB with external water heater).

The water cylinder probe measures the temperature of water in the cylinder. When this temperature is less than 5°C a water heater frost protection function begins: the circulating pump begins working and the burner is switched on.

On KR/KRB models with external water cylinder (optional) with NTC probe (10 kΩ @ β=3435; refer to water cylinder technical specifications), the frost protection function also protects the water heater.

When water heater probe detects a water temperature of +5 °C, the boiler switches on and stays on at its minimum heat output until the temperature of the water heater water reaches +10 °C or 15 minutes have elapsed.

During the water heater anti-freeze operation the temperature detected by the flow probe is constantly checked, and in case it reaches +60°C the burner is switched off.

The burner is switched on again if the operation request in anti-freeze mode is still present and the flow temperature is below +60°C.

1.3.6 Anti-seize function

If the boiler remains inactive and connected to the power mains, the circulation pump and the deviating valve (if any) will be shortly enabled every 24 hours so as to avoid any shut-down.

The same applies to the relay which can be freely programmed whenever this latter is used to power a recirculation pump or a deviating valve.

1.3.7 Timed post-circulation function

After each central heating, DHW or freeze protection request, the pump continues to be powered for 30 seconds.

If a new central heating, DHW or freeze protection request is received during this period, the post-circulation function is cancelled in order to fulfil the request.

1.3.8 Timed post-ventilation function

After each central heating, DHW or freeze protection request, the fan continues to work for 10 seconds.

If a new operating request is received during this period, the post-ventilation function is cancelled in order to fulfil the request.

1.3.9 Operation with external probe (optional)

Boiler can be connected to a probe measuring the external temperature (optional - not compulsory, supplied by the manufacturer).

Once the external temperature value is known, the boiler will automatically adjust the heating water temperature: increasing it as the external temperature decreases and decreasing it as the external temperature increases. This will both improve room comfort and reduce fuel consumption. The maximum temperature is respected all the same.

This boiler operating mode is called "sliding temperature operation".

Heating water temperature varies based on a programme written inside boiler electronic microprocessor.

When working with an external probe, the **CH +/-** buttons are no longer used to set heating water temperature, but to edit fictitious ambient temperature, namely the desired theoretical temperature.

During temperature setting, the fictitious ambient temperature  symbol flashes on the display and the value being set is shown.

For optimal curve adjustment, a position close to +20 °C is recommended.

For further details on "cruising temperature operation", refer to paragraph *Installation of the (optional) external probe and sliding temperature operation* on page 49.



WARNING

Only original external temperature probes supplied by the manufacturer must be used.

The use of non-original external probes, not supplied by the manufacturer, may affect the operation of the external probe itself and of the boiler.

1.3.10 Operation with (optional) remote control

The boiler can also be connected to a Remote Control (optional - not compulsory, supplied by the manufacturer) so as to manage several boiler parameters, such as:

- boiler status selection.
- ambient temperature selection.
- CH system water temperature selection.
- DHW temperature selection.
- CH system and (optional) external water heater activation time programming
- boiler diagnostics display.
- boiler reset and other parameters.

To connect the Remote Control, see *Installation and operation with Open Therm Remote Control (optional)* on page 48.



WARNING

Only use original Remote Control Units supplied by the manufacturer.

The use of non-original remote controls, not supplied by the manufacturer, may affect Remote Control and boiler operation.

1.4 Boiler shut-down

The boiler shuts down automatically if a malfunction occurs.

To determine the possible causes of malfunction (see *Troubleshooting* on page 68).

Below is a list of shut-down types and the procedure to follow in each case.

1.4.1 Burner shut-down

Fault code **E01** is displayed flashing on the display in the event of burner shut-down due to missing flame.

If this happens, proceed as follows:

- check that the gas cock is open and light a kitchen gas ring for example to check the gas supply;
- once having checked if the fuel is available, press the **Reset** button to restore burner operation: if, after two starting attempts, the boiler still fails to start and enters the shut-down mode again, contact a service centre or qualified personnel for maintenance.



WARNING

If the burner shuts down frequently, there is a recurring malfunction, so contact a service centre or a qualified service engineer.

1.4.2 Shut-down due to overheating

Fault code **E02** is shown on the LCD display in the event of flow water temperature overheating. Contact a service centre or a qualified service engineer to carry out the maintenance.

1.4.3 Shut-down due to incorrect air/flue gas system draught

The boiler is equipped with a safety device for flue gas exhaustion check.

Should an air/flue gas system malfunction occur, the control device will shut-down the boiler by interrupting the gas supply to the boiler and the LCD will display the **E03** code.

In this case, contact a Service Centre or a qualified service engineer to carry out the maintenance.

1.4.4 Shut-down due to low water pressure

Fault code **E04** is displayed on the LCD display in the event of shut-down triggered by the water pressure switch.

Fill the system by working on filler cock (A) (see Fig. 2 Filler cock).

Water pressure must be 1÷1.3 bars while the boiler is cold.

In order to restore water pressure, proceed as follows:

- Turn the filler cock anticlockwise to allow water to enter the boiler;
- Keep the filler cock open until the pressure gauge shows a value of 1÷1.3 bar;
- Turn cock clockwise to close it.

Should boiler shuts down frequently occur it means there is boiler malfunction in progress. Contact qualified personnel or an authorised service centre for maintenance.



DANGER

Make sure you close filler cock (A) carefully after filling procedure is completed.

If you do not, when the pressure increases, the safety valve may activate and discharge water.

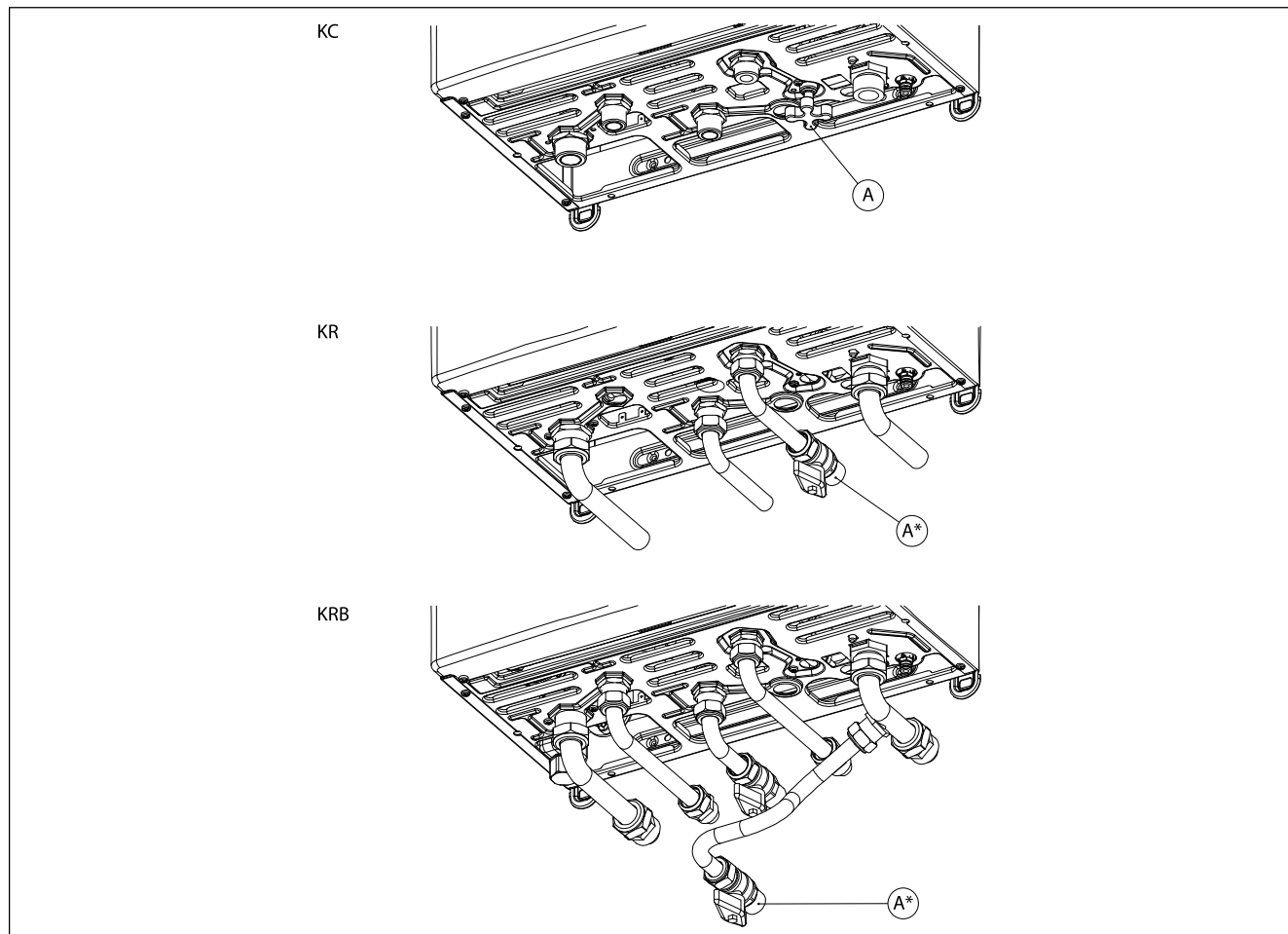

Fig. 2 Filler cock

(A*) option.

1.4.5 Alarm due to temperature probe malfunction

The following fault codes are shown on the display in the event of burner shut-down due to a temperature probe fault:

- **E05** for the CH probe: in this case the boiler does not work.
- **E06** for the DHW probe (KC model, only); in this case, the boiler works in central heating mode only, and the DHW function is disabled.
- **E12** for the water heater probe (KR/KRB models only); in this case, the boiler works in central heating mode only, and the water heater heating function is disabled.
- **E15** for the return probe; in this case the boiler does not work.



WARNING

In any case, contact a service centre or qualified personnel for maintenance.

1.4.6 Alarm due to (optional) Remote Control connection malfunction

The boiler recognises whether or not there is a Remote Control (optional, not compulsory).

If the boiler does not receive information from the Remote Control after the Remote Control itself is connected, the boiler attempts to re-establish communication for 60 seconds, after which the fault code **E31** is shown on the remote control display.

The boiler will continue to operate according to the settings on the touch screen and ignore the Remote Control settings.



WARNING

Contact a service centre or a qualified service engineer to carry out the maintenance.

The remote control can indicate faults or shutdown conditions and can also restore boiler operation after shutdown up to a maximum of 3 times in a 24 hour period.

If the maximum number of attempts is reached, fault code **E99** is shown on the boiler display.

To reset error **E99**, disconnect and re-connect again boiler from/to power mains.

1.4.7 Shut-down for fan malfunction

The fan operation is constantly monitored and in case of malfunction the burner goes off; the code **E40** flashes on the display.

This mode is maintained until the fan recovers normal working parameters.

If the boiler does not start and remains in this mode, contact a service centre or a qualified service engineer.

1.4.8 Alarm due to (optional) external temperature probe malfunction

In case of external temperature probe failure, boiler will continue to operate, but the "sliding temperature" operation will be disabled.

Heating water temperature is adjusted based on the value set with **CH +/-** buttons that, in this case, are no longer used to adjust calculated ambient temperature.

Contact a service centre or a qualified service engineer.

1.5 Maintenance



WARNING

The boiler must be serviced periodically as indicated in the relevant section of this manual.

Appropriate boiler maintenance ensures efficient operation, environment preservation, and safety for people, animals and objects.

Boilers must be maintained by qualified personnel only, under the requirements set forth by the prevailing rules.

1.6 Notes for the user



WARNING

The user may only access parts of the boiler that can be reached without using special equipment or tools. The user is not authorised to remove the boiler casing or to operate on any internal parts.

No one, including qualified personnel, is authorised to modify the boiler.

The manufacturer shall not be held responsible in case of damage to people, animals, or property due to failure to follow the above mentioned instructions.

2. Technical features and dimensions

2.1 Technical features

This boiler is equipped with a fully pre-mixed gas burner. The following models are available:

- **KC** condensing boiler with sealed chamber and forced draught, supplying CH water and instant DHW production;
- **KR** condensing boiler with sealed chamber and forced draught, supplying CH water only.
- **KRB** condensing boiler with sealed chamber and forced draught, supplying CH water only; with 3-way deviating valve for connection to external water heater (optional).

The following power rates are available:

- **KC/KR/KRB 12:** with heat input of 12.0 kW
- **KC/KR/KRB 24:** with heat input of 23.7 kW
- **KC/KR/KRB 28:** with heat input of 26.4 kW

All models are equipped with electronic ignition and ionisation flame sensing device.

The boilers meet local applicable Directives enforced in the country of destination, which are stated on their rating plate.

Installation in any other country may be a source of danger for people, animals and property.

The key technical features of the boilers are listed below.

2.1.1 Manufacturing characteristics

- IPX4D electrically protected control panel.
- Integrated, modulating electronic safety board.
- Electronic start-up with built-in igniter and ionisation flame detection.
- Stainless steel, fully pre-mixed burner.
- Mono-thermal, high efficiency, composite and stainless steel heat exchanger with air purging device.
- Twin shutter modulating gas valve with constant air/gas ratio.
- Modulating, electronically managed combustion fan.
- High-efficiency CH circulation pump with built-in air purging device.
- Minimum pressure switch.
- Heating flow water temperature probe (double).
- DHW temperature probe (KC).
- Flue gas thermostat on discharge tower
- Flue gas probe on primary heat exchanger.
- Integrated, automatic by-pass.
- 9-lt- expansion vessel
- System filler cock.
- System unloading cock. (KC)
- DHW plate heat exchanger made of stainless steel (KC).
- Motorised 3-way valve (models KC and KRB).
- DHW priority switch (KC).
- DHW flow-limiting device - 10 litre/min (KC 12), 13 litre/min (KC 24), 14 l/min (KC 28).

2.1.2 User interface

- Liquid crystal LCD interface for displaying and setting the boiler operating status: OFF, SUMMER, WINTER and CH ONLY.
- CH water temperature regulator: 20-78°C (standard range) or 20-45°C (reduced range).
- DHW water temperature regulator: 35-57°C (KC) - 35÷65°C (KR/KRB with optional water heater).
- System water pressure gauge.

2.1.3 Operating features

- CH electronic flame modulation with timer-controlled rising ramp (60 seconds, adjustable).
- DHW electronic flame modulation (models KC and KR/KRB with optional water heater).
- DHW priority function (model KC and models KR/KRB with optional water heater)
- Flow freeze protection function: ON 5°C; OFF 30°C or after 15 minutes of operation if CH temperature > 5 °C.
- DHW freeze protection function: ON 5°C; OFF 30°C or after 15 minutes of operation if CH temperature > 5 °C.
- Water heater freeze protection function (for models KB/KRB with external water heater equipped with NTC probe): ON at 5 °C; OFF at 10 °C or after 15 of activity if water heater temperature is > 5 °C.
- Timer-controlled flue cleaning function: 15 minutes.
- Anti-legionella function (models KR/KRB with optional water heater).
- CH Maximum heat input parameter adjustment.
- Ignition heat input adjustment parameter.
- Possibility to select the heating range: standard or reduced.
- Ignition flame propagation function.
- CH thermostat timer: 240 seconds (adjustable).
- Heating pump post-circulation function in CH, freeze protection and flue cleaning modes: 30 seconds (adjustable).
- DHW post-circulation function (KC and KR/KRB with optional water heater): 30 seconds.
- Post-circulation function for heating temperature > 78 °C: 30 seconds.
- Post-ventilation function after working: 10 seconds.
- Post-ventilation function for CH temperature >95 °C.
- Circulation pump and deviating valve anti shut-down function: 30 seconds of operation after 24 hours of inactivity.
- Anti water hammer function: adjustable from 0 to 3 seconds via parameter **P15**.
- Ready for connection to an ambient thermostat.
- Ready for operation with an external probe (optional, supplied by the manufacturer).
- Ready for operation with an OpenTherm remote control (optional, supplied by the manufacturer).
- Ready for operation with a module for different temperature zones.

2.2 Dimensions

KC model

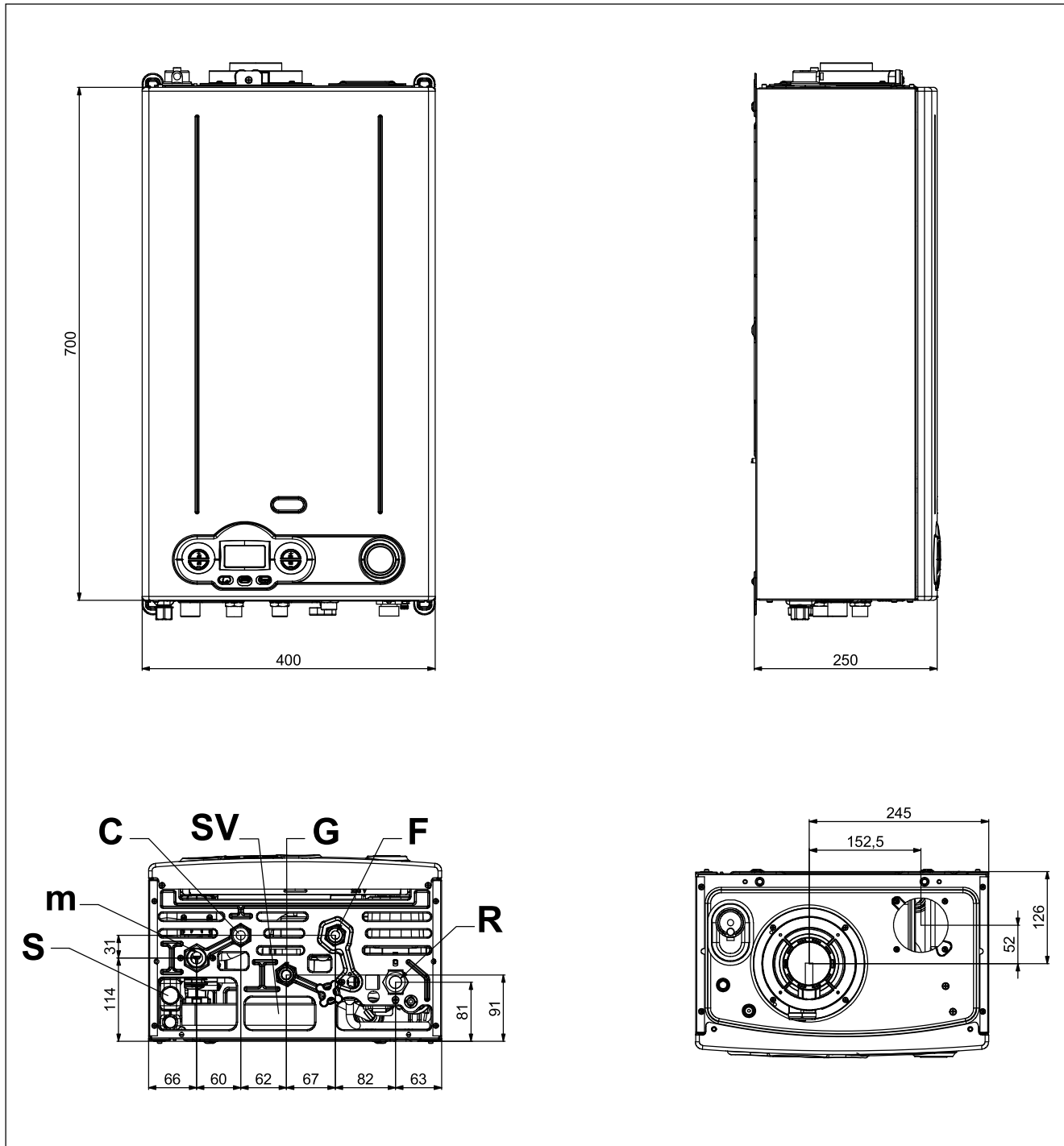

Fig. 3 Model KC dimensions

- S Trap inspection cap
- M CH system flow (3/4")
- C DHW outlet (1/2")
- SV 3-bar safety valve discharge outlet
- G Gas inlet (1/2")
- F Cold water inlet (1/2")
- R CH system return (3/4")

KR model

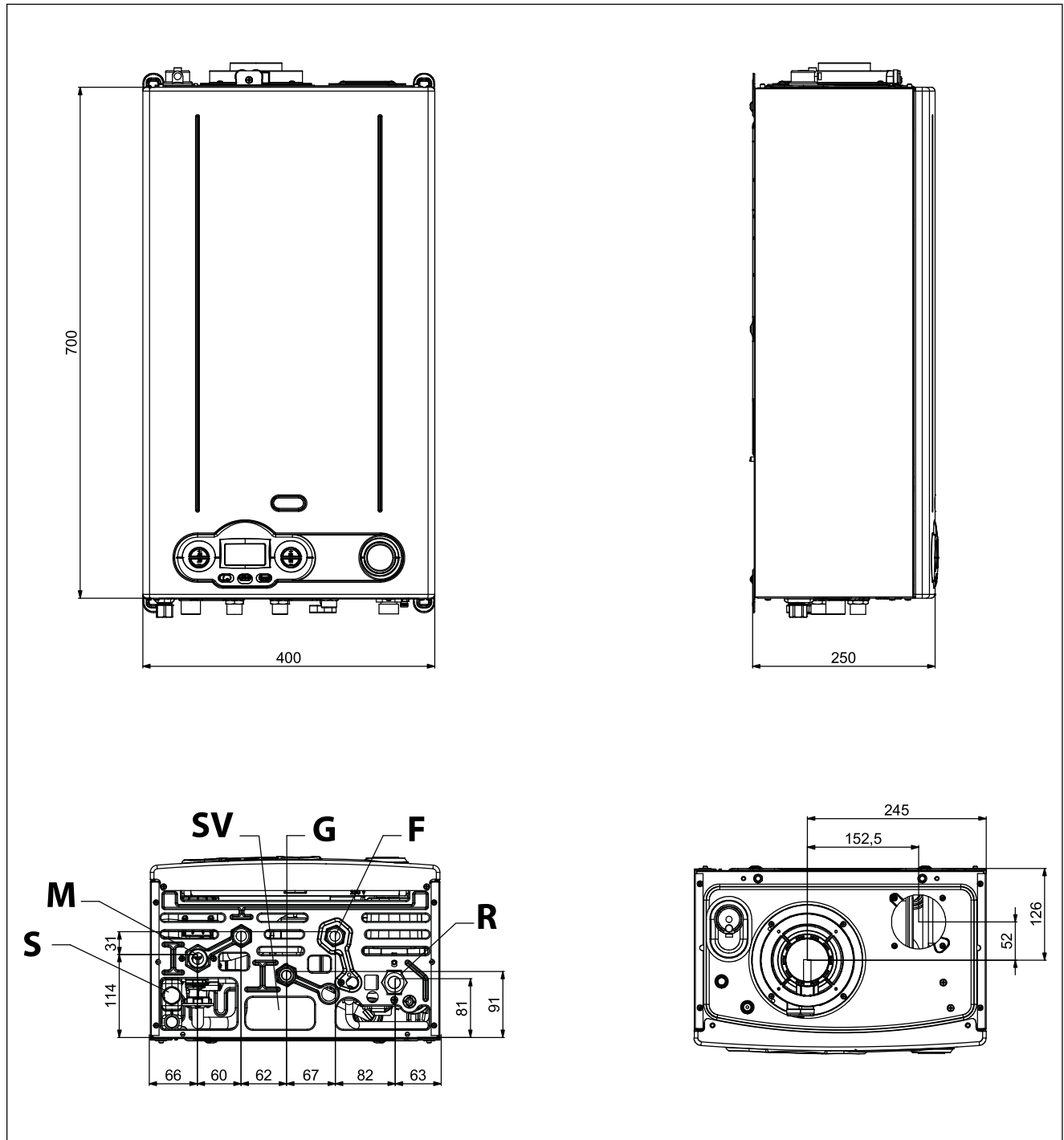

Fig. 4 Model KR dimensions

- S Trap inspection cap
- M CH system flow (3/4")
- SV 3-bar safety valve discharge outlet
- G Gas inlet (1/2")
- F Cold water inlet (1/2")
- R CH system return (3/4")

KRB model

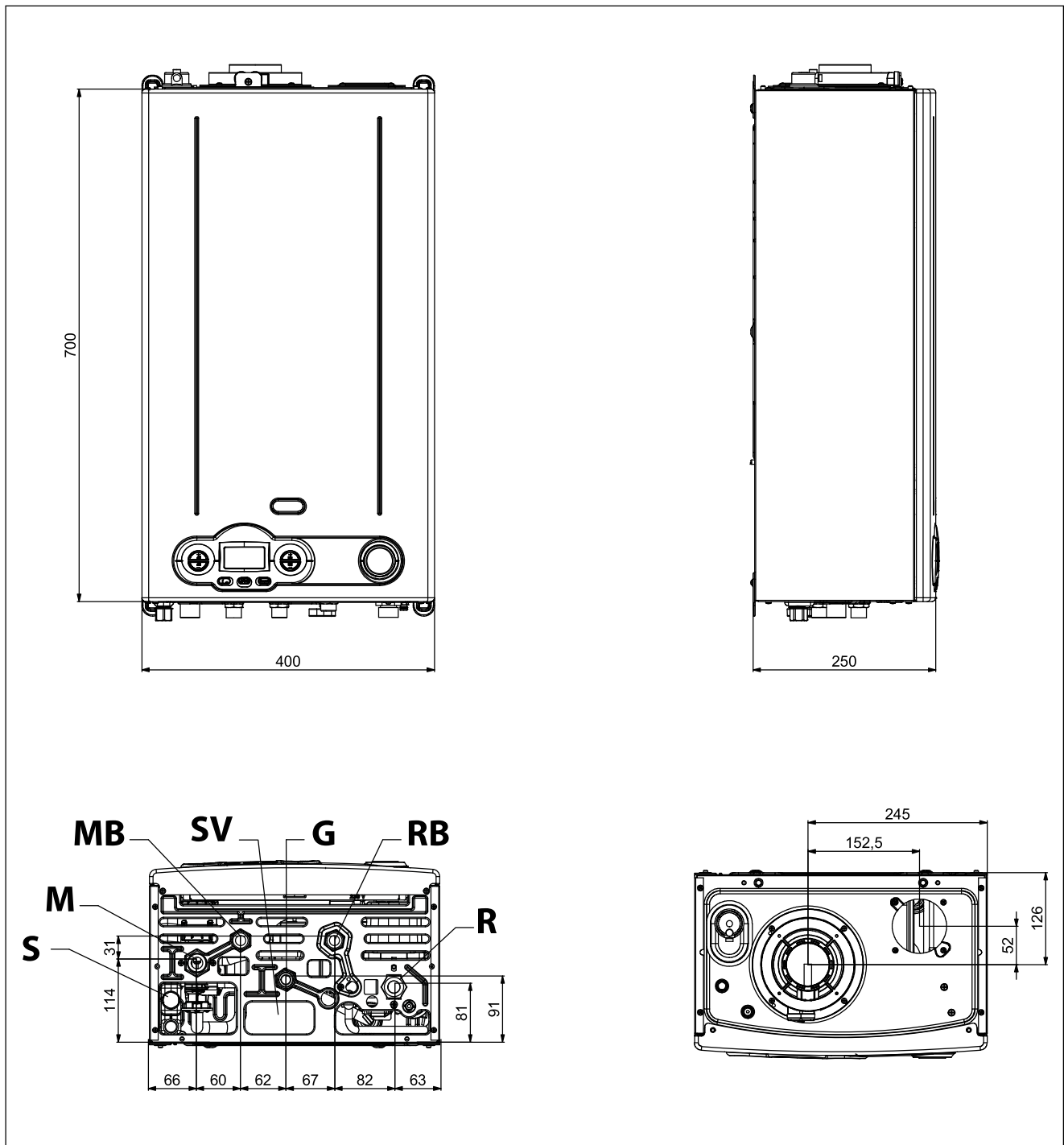

Fig. 5 Model KRB dimensions

- S Trap inspection cap
- M CH system flow (3/4")
- MB Water heater secondary flow (1/2")
- SV 3-bar safety valve discharge outlet
- G Gas inlet (1/2")
- RB Water heater secondary return (1/2")
- R CH system return (3/4")

2.3 Boiler layouts

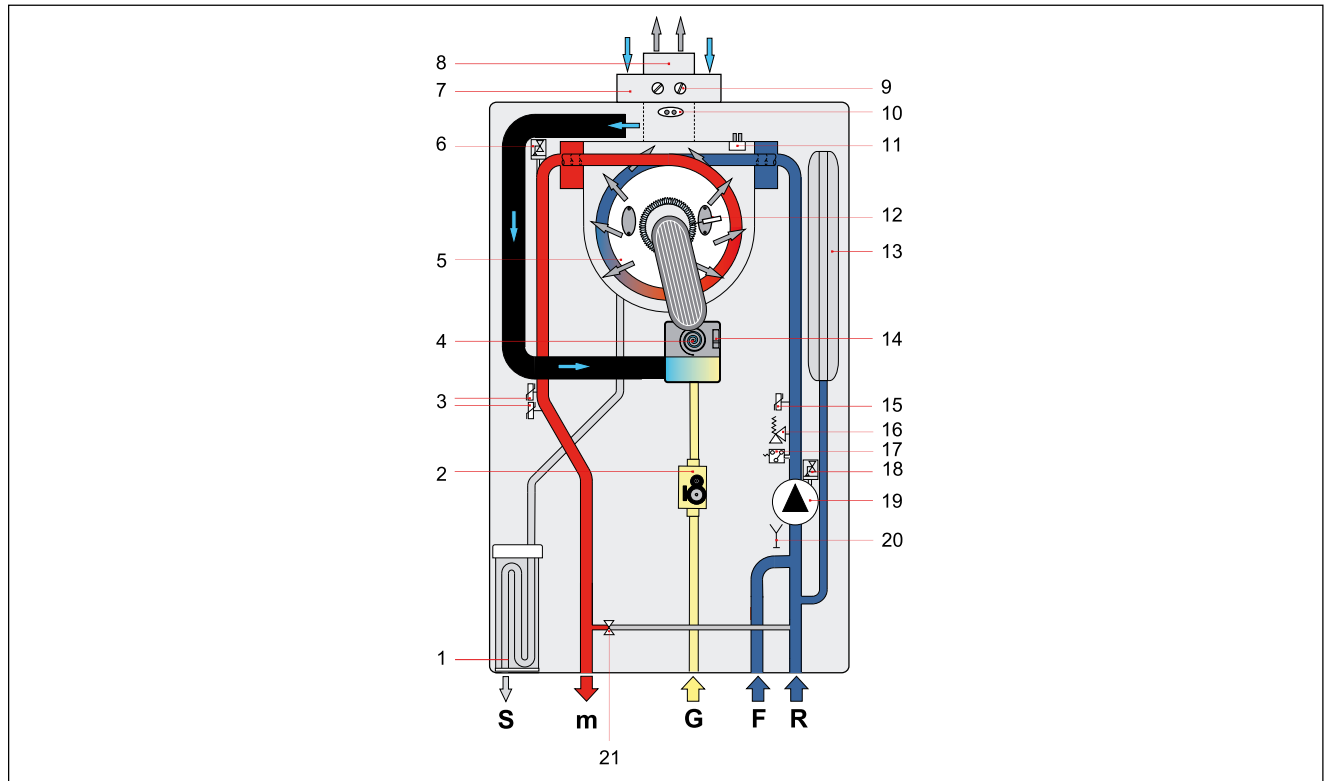

Fig. 6 Model KR wiring diagram

- | | |
|---|---------------------------|
| 1. Condensate trap | S Condensate drain |
| 2. Modulating gas valve | M CH system flow |
| 3. Flow temperature twin probe | G Gas inlet |
| 4. Modulating fan | F Cold water inlet |
| 5. Main condensing heat exchanger | R CH system return |
| 6. Air-purging device | |
| 7. Air intake duct | |
| 8. Flue gas venting duct | |
| 9. Flue gas analysis ports | |
| 10. Flue gas thermostat on venting duct | |
| 11. Flue gas probe on heat exchanger | |
| 12. Ignition/detection electrode | |
| 13. Expansion vessel | |
| 14. Fan check probe | |
| 15. Return temperature probe | |
| 16. 3-bar safety valve | |
| 17. Minimum pressure switch | |
| 18. Air-purging device | |
| 19. Circulation pump | |
| 20. System unloading cock. | |
| 21. Automatic by-pass | |

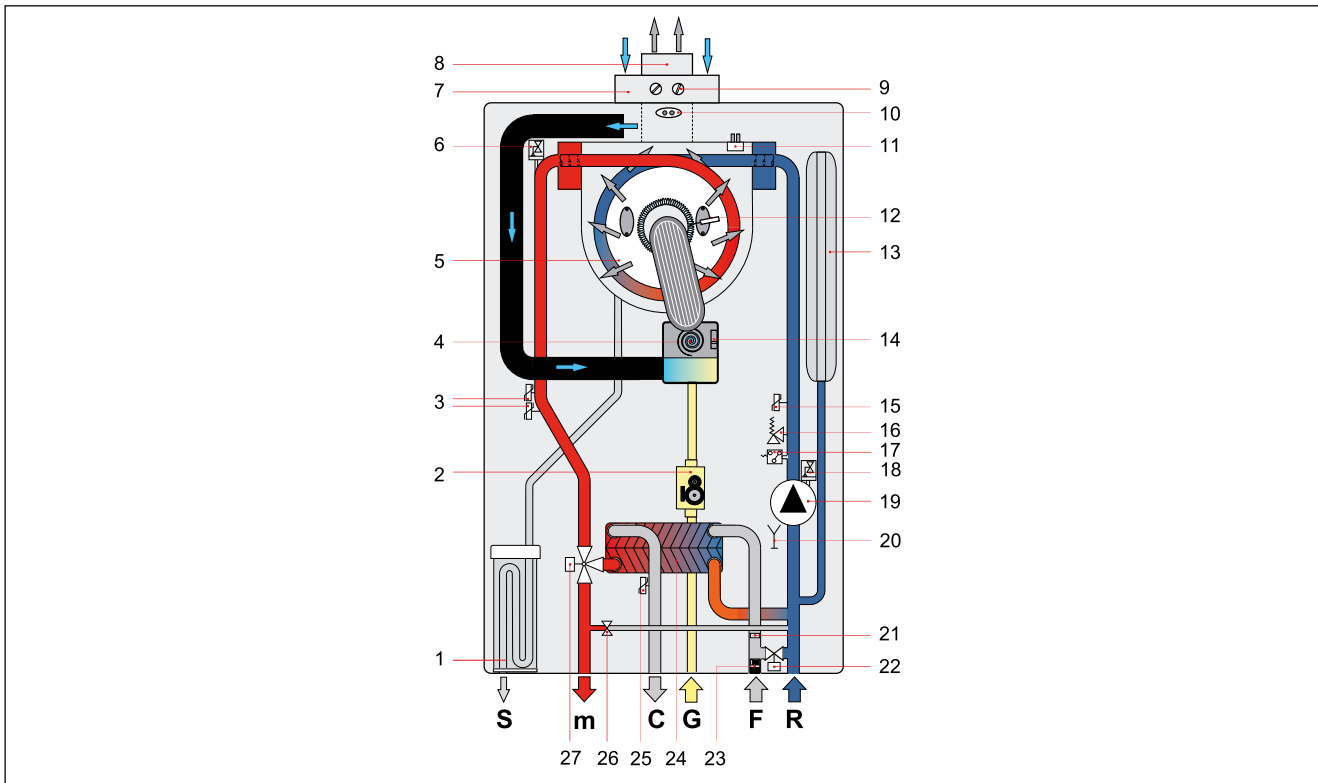

Fig. 7 Model KC wiring diagram

- | | |
|---|---------------------------|
| 1. Condensate trap | S Condensate drain |
| 2. Modulating gas valve | M CH system flow |
| 3. Flow temperature twin probe | C DHW outlet |
| 4. Modulating fan | G Gas inlet |
| 5. Main condensing heat exchanger | F Cold water inlet |
| 6. Air-purging device | R CH system return |
| 7. Air intake duct | |
| 8. Flue gas venting duct | |
| 9. Flue gas analysis ports | |
| 10. Flue gas thermostat on venting duct | |
| 11. Flue gas probe on heat exchanger | |
| 12. Ignition/detection electrode | |
| 13. Expansion vessel | |
| 14. Fan check probe | |
| 15. Return temperature probe | |
| 16. 3-bar safety valve | |
| 17. Minimum pressure switch | |
| 18. Air-purging device | |
| 19. Circulation pump | |
| 20. System unloading cock. | |
| 21. DHW flow rate limiting device | |
| 22. Filler cock | |
| 23. Cold water flow switch with filter | |
| 24. Secondary plate exchanger | |
| 25. DHW temperature probe | |
| 26. Automatic by-pass | |
| 27. Motorised 3-way valve | |

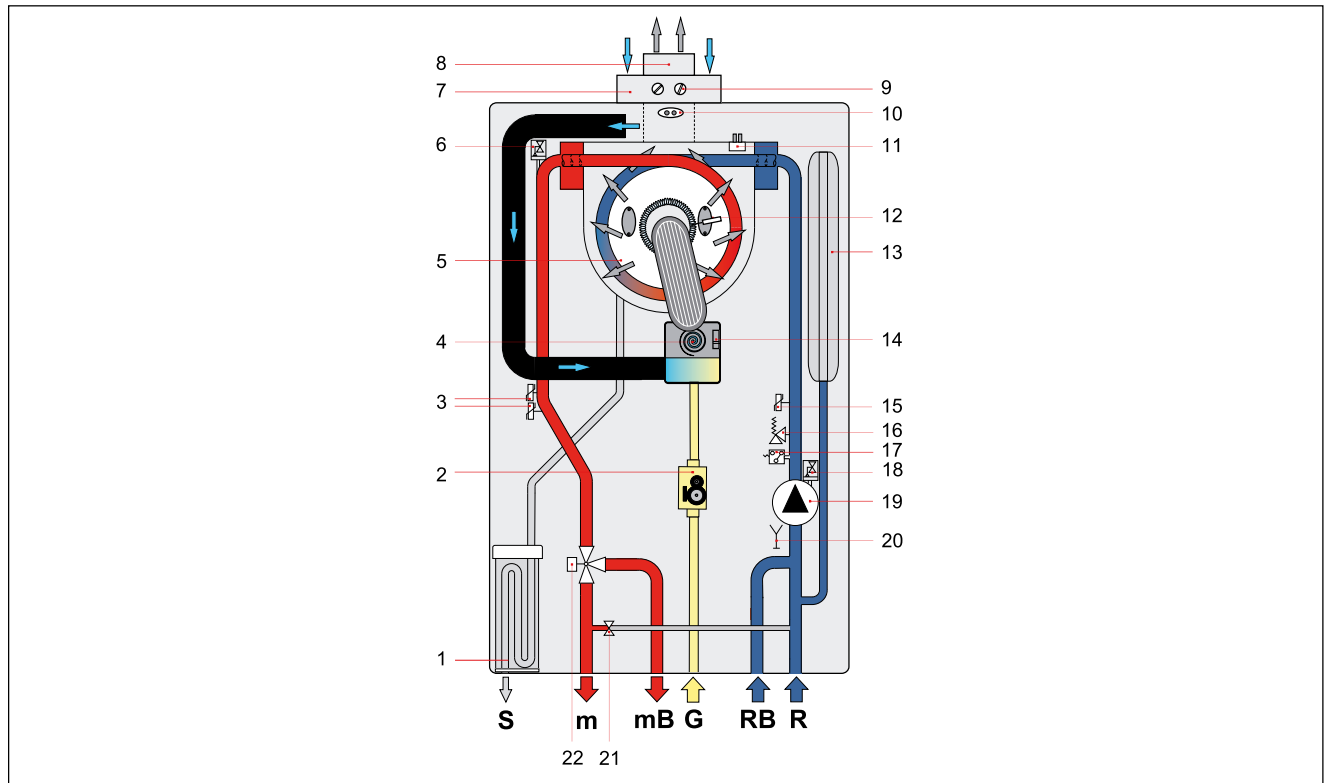

Fig. 8 Model KRB wiring diagram

- | | |
|---|--|
| 1. Condensate trap | S Condensate drain |
| 2. Modulating gas valve | M CH system flow |
| 3. Flow temperature twin probe | MB Water heater flow |
| 4. Modulating fan | G Gas inlet |
| 5. Main condensing heat exchanger | RB Return from the water heater |
| 6. Air-purging device | R CH system return |
| 7. Air intake duct | |
| 8. Flue gas venting duct | |
| 9. Flue gas analysis ports | |
| 10. Flue gas thermostat on venting duct | |
| 11. Flue gas probe on heat exchanger | |
| 12. Ignition/detection electrode | |
| 13. Expansion vessel | |
| 14. Fan check probe | |
| 15. Return temperature probe | |
| 16. 3-bar safety valve | |
| 17. Minimum pressure switch | |
| 18. Air-purging device | |
| 19. Circulation pump | |
| 20. System unloading cock. | |
| 21. Automatic by-pass | |
| 22. Motorised 3-way valve | |

2.4 Operating data

Burner pressures reported in the following page must be verified after the boiler has been operating for 3 minutes.

Gas category: II2H3P

Fuel	Gas mains pressure [mbar]	Nozzle [mm]	Diaphragm diameter [mm]	Flue CO2 value [%]
Natural gas G20	20	3.05	-	9.0 ÷ 9.3
Propane Gas G31	37	2.50	-	10.0 ÷ 10.3

Tab. 1 KC 12 adjustment data

Fuel	Gas mains pressure [mbar]	Nozzle [mm]	Diaphragm diameter [mm]	Flue CO2 value [%]
Natural gas G20	20	3.70	-	9.0 ÷ 9.3
Propane Gas G31	37	3.00	-	10.0 ÷ 10.0

Tab. 2 KC 24 adjustment data

Fuel	Gas mains pressure [mbar]	Nozzle [mm]	Diaphragm diameter [mm]	Flue CO2 value [%]
Natural gas G20	20	4.00	-	9.0 ÷ 9.3
Propane Gas G31	37	3.30	-	10.0 ÷ 10.3

Tab. 3 KC 28 adjustment data

2.5 General characteristics

Description	um	KC 12	KC 24	KC 28
CH nominal heat input	kW	12.0	23.7	26.4
Minimum heat input	kW	2.0	3	3.3
Maximum heat output (80-60°C) - CH	kW	11.7	22.9	25.4
Minimum heat output (80-60°C) - CH	kW	1.8	2.7	3.0
Maximum heat output (50-30°C) - CH	kW	12.6	24.9	27.9
Minimum heat output (50-30°C) - CH	kW	2.1	3.22	3.45
Minimum CH system pressure	bar	0.5	0.5	0.5
Maximum CH system pressure	bar	3.0	3.0	3.0
DHW maximum heat input	kW	18	27.3	30.4
DHW minimum heat input	kW	2	3.0	3.3
DHW circuit min. pressure	bar	0.1	0.5	0.5
DHW circuit max. pressure	bar	6.0	6.0	6.0
DHW specific flow rate ($\Delta T=25K$)	l/min	10.3	16.1	18.0
DHW specific flow rate ($\Delta t=30K$)	l/min	8.6	13.4	15.0
Electric power supply – voltage / frequency	V - Hz	230 -50	230 -50	230 -50
Power mains supply fuse	A	3.15	3.15	3.15
Maximum power consumption	W	75	83	84
Pump absorption	W	41	41	41
Electric protection rating	IP	X4D	X4D	X4D
Net weight	kg	28.5	30.0	31.5
Natural gas consumption at maximum CH output (Value referred to 15 °C - 1013 mbar)	cu. m/h	1.27	2.51	2.79
Propane gas consumption at maximum CH output	kg/h	0.93	1.84	2.05
Maximum CH working temperature	°C	83	83	83
Maximum DHW working temperature	°C	62	62	62
Total capacity of expansion vessel	l	9	9	9
Maximum recommended system capacity (Maximum water temperature 83°C, expansion vessel pressure 1 bar)	l	200	200	200

Tab. 4 Model KC general data

Description	um	KR/KRB 12	KR/KRB 24	KR/KRB 28
CH nominal heat input	kW	12.0	23.7	26.4
Minimum heat input	kW	2.0	3	3.3
Maximum heat output (80-60°C) - CH	kW	11.7	22.9	25.4
Minimum heat output (80-60°C) - CH	kW	1.8	2.7	3.0
Maximum heat output (50-30°C) - CH	kW	12.6	24.9	27.9
Minimum heat output (50-30°C) - CH	kW	2.1	3.22	3.45
Minimum CH system pressure	bar	0.5	0.5	0.5
Maximum CH system pressure	bar	3.0	3.0	3.0
Electric power supply – voltage / frequency	V - Hz	230 -50	230 -50	230 -50
Power mains supply fuse	A	3.15	3.15	3.15
Maximum power consumption	W	75	83	84
Pump absorption	W	41	41	41
Electric protection rating	IP	X4D	X4D	X4D
Net weight	kg	28.5	30.0	31.5
Natural gas consumption at maximum CH output (Value referred to 15 °C - 1013 mbar)	cu. m/h	1.27	2.51	2.79
Propane gas consumption at maximum CH output	kg/h	0.93	1.84	2.05
Maximum CH working temperature	°C	83	83	83
Maximum DHW working temperature (*)	°C	65	65	65
Total capacity of expansion vessel	l	9	9	9
Maximum recommended system capacity (Maximum water temperature 83°C, expansion vessel pressure 1 bar)	l	200	200	200

Tab. 5 Model KR/KRB general data

Description	um	Max. output	Min. output	30% load
Casing heat loss with burner on	%	0.26	7.78	-
Casing heat loss with burner off	%	0.55		
Flue system heat loss with burner on	%	2.64	1.92	-
Flue system mass capacity	g/s	8.25	0.89	-
Flue temp. – air temp.	°C	57.9	34.5	-
Heat efficiency (80-60°C)	%	97.1	90.3	-
Heat efficiency (50-30°C)	%	105.1	105.0	-
30% heat output efficiency rating	%	-	-	106.0
NOx emission class	-	5		

Tab. 6 KC-KR-KRB 12 combustion data

Description	um	Max. output	Min. output	30% load
Casing heat loss with burner on	%	0.97	6.49	-
Casing heat loss with burner off	%	0.26		
Flue system heat loss with burner on	%	2.62	2.09	-
Flue system mass capacity	g/s	12.43	1.33	-
Flue temp. – air temp.	°C	61	33	-
Heat efficiency (80-60°C)	%	96.7	91.4	-
Heat efficiency (50-30°C)	%	105.1	104.9	-
30% heat output efficiency rating	%	-	-	106.5
NOx emission class	-	5		

Tab. 7 KC-KR-KRB 24 combustion data

Description	um	Max. output	Min. output	30% load
Casing heat loss with burner on	%	1.4	5.7	-
Casing heat loss with burner off	%	0.25		
Flue system heat loss with burner on	%	2.4	2.0	-
Flue system mass capacity	g/s	13.93	1.47	-
Flue temp. – air temp.	°C	60	45	-
Heat efficiency (80-60°C)	%	96.4	92.3	-
Heat efficiency (50-30°C)	%	105.5	104.5	-
30% heat output efficiency rating	%	-	-	107.0
NOx emission class	-	5		

Tab. 8 KC-KR-KRB 28 combustion data

2.6 ERP and Labelling data

Model(s): DELFIS KC 12	
Condensing boiler: yes	
Low-temperature (**) boiler: yes	
B1 boiler: no	
Cogeneration space heater: no	If yes, equipped with a supplementary heater: -
Combination heater: yes	

Item	Symbol	Value	Unit	Item	Symbol	Value	Unit
Rated heat output	P_n	12	kW	Seasonal space heating energy efficiency	η_s	90	%
For boiler space heaters and boiler combination heaters: Useful heat output				For boiler space heaters and boiler combination heaters: Useful efficiency			
At rated heat output and high-temperature regime (*)	P_4	11,7	kW	At rated heat output and high-temperature regime (*)	η_4	86,2	%
At 30 % of rated heat output and low-temperature regime (**)	P_1	3,7	kW	At 30 % of rated heat output and low-temperature regime (**)	η_1	95,5	%
Auxiliary electricity consumption				Other items			
At full load	$e_{l_{max}}$	0,020	kW	Standby heat loss	P_{stby}	0,030	kW
At part load	$e_{l_{min}}$	0,013	kW	Ignition burner power consumption	P_{ign}	0,000	kW
In standby mode	P_{SB}	0,002	kW	Annual energy consumption	Q_{HE}	21	GJ
				Emissions of nitrogen oxides	NO_x	28	mg/kWh
For combination heaters:							
Declared load profile	M			Water heating energy efficiency	η_{wh}	78	%
Daily electricity consumption	Q_{elec}	0,064	kWh	Daily fuel consumption	Q_{fuel}	7,300	kWh
Annual electricity consumption	AEC	14	kWh	Annual fuel consumption	AFC	5	GJ
Contact details: FONDITAL S.p.A. - Via Cerreto, 40 I-25079 VOBARNO (Brescia) Italia - Italy							

(*) High-temperature regime means 60 °C return temperature at heater inlet and 80 °C feed temperature at heater outlet.

(**) Low temperature means for condensing boilers 30 °C, for low-temperature boilers 37 °C and for other heaters 50 °C return temperature (at heater inlet).

Seasonal space heating energy efficiency class	A
Water heating energy efficiency class	A

Tab. 9 ERP and Labelling data - KC 12

Model(s): DELFIS KC 24	
Condensing boiler: yes	
Low-temperature (**) boiler: yes	
B1 boiler: no	
Cogeneration space heater: no	If yes, equipped with a supplementary heater: -
Combination heater: yes	

Item	Symbol	Value	Unit	Item	Symbol	Value	Unit
Rated heat output	P_n	23	kW	Seasonal space heating energy efficiency	η_s	91	%
For boiler space heaters and boiler combination heaters: Useful heat output				For boiler space heaters and boiler combination heaters: Useful efficiency			
At rated heat output and high-temperature regime (*)	P_4	22,9	kW	At rated heat output and high-temperature regime (*)	η_4	86,5	%
At 30 % of rated heat output and low-temperature regime (**)	P_1	7,3	kW	At 30 % of rated heat output and low-temperature regime (**)	η_1	95,9	%
Auxiliary electricity consumption				Other items			
At full load	$e_{l_{max}}$	0,030	kW	Standby heat loss	P_{stby}	0,061	kW
At part load	$e_{l_{min}}$	0,016	kW	Ignition burner power consumption	P_{ign}	0,000	kW
In standby mode	P_{SB}	0,002	kW	Annual energy consumption	Q_{HE}	41	GJ
For combination heaters:				Emissions of nitrogen oxides	NO_x	29	mg/kWh
Declared load profile	XL			Water heating energy efficiency	η_{wh}	84	%
Daily electricity consumption	Q_{elec}	0,110	kWh	Daily fuel consumption	Q_{fuel}	22,450	kWh
Annual electricity consumption	AEC	17	kWh	Annual fuel consumption	AFC	24	GJ

Contact details: FONDITAL S.p.A. - Via Cerreto, 40 I-25079 VOBARNO (Brescia) Italia - Italy

(*) High-temperature regime means 60 °C return temperature at heater inlet and 80 °C feed temperature at heater outlet.

(**) Low temperature means for condensing boilers 30 °C, for low-temperature boilers 37 °C and for other heaters 50 °C return temperature (at heater inlet).

Seasonal space heating energy efficiency class	A
Water heating energy efficiency class	A

Tab. 10 ERP and Labelling data - KC 24

Model(s): DELFIS KC 28	
Condensing boiler: yes	
Low-temperature (**) boiler: yes	
B1 boiler: no	
Cogeneration space heater: no	If yes, equipped with a supplementary heater: -
Combination heater: yes	

Item	Symbol	Value	Unit	Item	Symbol	Value	Unit
Rated heat output	P_n	25	kW	Seasonal space heating energy efficiency	η_s	91	%
For boiler space heaters and boiler combination heaters: Useful heat output				For boiler space heaters and boiler combination heaters: Useful efficiency			
At rated heat output and high-temperature regime (*)	P_4	25,4	kW	At rated heat output and high-temperature regime (*)	η_4	86,5	%
At 30 % of rated heat output and low-temperature regime (**)	P_1	8,2	kW	At 30 % of rated heat output and low-temperature regime (**)	η_1	96,4	%
Auxiliary electricity consumption				Other items			
At full load	$e_{l_{max}}$	0,034	kW	Standby heat loss	P_{stby}	0,077	kW
At part load	$e_{l_{min}}$	0,016	kW	Ignition burner power consumption	P_{ign}	0,000	kW
In standby mode	P_{SB}	0,002	kW	Annual energy consumption	Q_{HE}	45	GJ
For combination heaters:				Emissions of nitrogen oxides	NO_x	28	mg/kWh
Declared load profile	XL			Water heating energy efficiency	η_{wh}	80	%
Daily electricity consumption	Q_{elec}	0,107	kWh	Daily fuel consumption	Q_{fuel}	23,460	kWh
Annual electricity consumption	AEC	18	kWh	Annual fuel consumption	AFC	23	GJ

Contact details: FONDITAL S.p.A. - Via Cerreto, 40 I-25079 VOBARNO (Brescia) Italia - Italy

(*) High-temperature regime means 60 °C return temperature at heater inlet and 80 °C feed temperature at heater outlet.
(**) Low temperature means for condensing boilers 30 °C, for low-temperature boilers 37 °C and for other heaters 50 °C return temperature (at heater inlet).

Seasonal space heating energy efficiency class	A
Water heating energy efficiency class	A

Tab. 11 ERP and Labelling data - KC 28

Model(s): DELFIS KR 12; DELFIS KRB 12

Condensing boiler: yes

Low-temperature (**) boiler: yes

B1 boiler: no

Cogeneration space heater: no

If yes, equipped with a supplementary heater: -

Combination heater: no

Item	Symbol	Value	Unit	Item	Symbol	Value	Unit
Rated heat output	P_n	12	kW	Seasonal space heating energy efficiency	η_s	90	%
For boiler space heaters and boiler combination heaters: Useful heat output				For boiler space heaters and boiler combination heaters: Useful efficiency			
At rated heat output and high-temperature regime (*)	P_4	11,7	kW	At rated heat output and high-temperature regime (*)	η_4	86,2	%
At 30 % of rated heat output and low-temperature regime (**)	P_1	3,7	kW	At 30 % of rated heat output and low-temperature regime (**)	η_1	95,5	%
Auxiliary electricity consumption				Other items			
At full load	el_{max}	0,020	kW	Standby heat loss	P_{stby}	0,030	kW
At part load	el_{min}	0,013	kW	Ignition burner power consumption	P_{ign}	0,000	kW
In standby mode	P_{sb}	0,002	kW	Annual energy consumption	Q_{HE}	21	GJ
For combination heaters:				Emissions of nitrogen oxides	NO_x	28	mg/kWh
Declared load profile	-			Water heating energy efficiency	η_{wh}	-	%
Daily electricity consumption	Q_{elec}	-	kWh	Daily fuel consumption	Q_{fuel}	-	kWh
Annual electricity consumption	AEC	-	kWh	Annual fuel consumption	AFC	-	GJ
Contact details: FONDITAL S.p.A. - Via Cerreto, 40 I-25079 VOBARNO (Brescia) Italia - Italy							
(*) High-temperature regime means 60 °C return temperature at heater inlet and 80 °C feed temperature at heater outlet.							
(**) Low temperature means for condensing boilers 30 °C, for low-temperature boilers 37 °C and for other heaters 50 °C return temperature (at heater inlet).							
Seasonal space heating energy efficiency class							A

Tab. 12 ERP and Labelling data - KR/KRB 12

Model(s): DELFIS KR 24; DELFIS KRB 24	
Condensing boiler: yes	
Low-temperature (***) boiler: yes	
B1 boiler: no	
Cogeneration space heater: no	If yes, equipped with a supplementary heater: -
Combination heater: no	

Item	Symbol	Value	Unit	Item	Symbol	Value	Unit
Rated heat output	P_n	23	kW	Seasonal space heating energy efficiency	η_s	91	%
For boiler space heaters and boiler combination heaters: Useful heat output				For boiler space heaters and boiler combination heaters: Useful efficiency			
At rated heat output and high-temperature regime (*)	P_4	22,9	kW	At rated heat output and high-temperature regime (*)	η_4	86,5	%
At 30 % of rated heat output and low-temperature regime (**)	P_1	7,3	kW	At 30 % of rated heat output and low-temperature regime (**)	η_1	95,9	%
Auxiliary electricity consumption				Other items			
At full load	$e_{l_{max}}$	0,030	kW	Standby heat loss	P_{stby}	0,061	kW
At part load	$e_{l_{min}}$	0,016	kW	Ignition burner power consumption	P_{ign}	0,000	kW
In standby mode	P_{SB}	0,002	kW	Annual energy consumption	Q_{HE}	41	GJ
For combination heaters:				Emissions of nitrogen oxides	NO_x	29	mg/kWh
Declared load profile	-			Water heating energy efficiency	η_{wh}	-	%
Daily electricity consumption	Q_{elec}	-	kWh	Daily fuel consumption	Q_{fuel}	-	kWh
Annual electricity consumption	AEC	-	kWh	Annual fuel consumption	AFC	-	GJ

Contact details: FONDITAL S.p.A. - Via Cerreto, 40 I-25079 VOBARNO (Brescia) Italia - Italy

(*) High-temperature regime means 60 °C return temperature at heater inlet and 80 °C feed temperature at heater outlet.

(**) Low temperature means for condensing boilers 30 °C, for low-temperature boilers 37 °C and for other heaters 50 °C return temperature (at heater inlet).

Seasonal space heating energy efficiency class	A
---	----------

Tab. 13 ERP and Labelling data - KR/KRB 24

Model(s): DELFIS KR 28; DELFIS KRB 28

Condensing boiler: yes

Low-temperature (**) boiler: yes

B1 boiler: no

Cogeneration space heater: no

If yes, equipped with a supplementary heater: -

Combination heater: no

Item	Symbol	Value	Unit	Item	Symbol	Value	Unit
Rated heat output	P_n	25	kW	Seasonal space heating energy efficiency	η_s	91	%
For boiler space heaters and boiler combination heaters: Useful heat output				For boiler space heaters and boiler combination heaters: Useful efficiency			
At rated heat output and high-temperature regime (*)	P_4	25,4	kW	At rated heat output and high-temperature regime (*)	η_4	86,5	%
At 30 % of rated heat output and low-temperature regime (**)	P_1	8,2	kW	At 30 % of rated heat output and low-temperature regime (**)	η_1	96,4	%
Auxiliary electricity consumption				Other items			
At full load	el_{max}	0,034	kW	Standby heat loss	P_{stby}	0,077	kW
At part load	el_{min}	0,016	kW	Ignition burner power consumption	P_{ign}	0,000	kW
In standby mode	P_{sb}	0,002	kW	Annual energy consumption	Q_{HE}	45	GJ
For combination heaters:				Emissions of nitrogen oxides	NO_x	28	mg/kWh
Declared load profile	-			Water heating energy efficiency	η_{wh}	-	%
Daily electricity consumption	Q_{elec}	-	kWh	Daily fuel consumption	Q_{fuel}	-	kWh
Annual electricity consumption	AEC	-	kWh	Annual fuel consumption	AFC	-	GJ
Contact details: FONDITAL S.p.A. - Via Cerreto, 40 I-25079 VOBARNO (Brescia) Italia - Italy							
(*) High-temperature regime means 60 °C return temperature at heater inlet and 80 °C feed temperature at heater outlet.							
(**) Low temperature means for condensing boilers 30 °C, for low-temperature boilers 37 °C and for other heaters 50 °C return temperature (at heater inlet).							
Seasonal space heating energy efficiency class							A

Tab. 14 ERP and Labelling data - KR/KRB 28

3. Instructions for the installer

3.1 Installation standards

This boiler must be installed in compliance with the laws and standards in force in the country of installation, which are herein considered as entirely transcribed.

To find out about the gas category and technical specifications, refer to operation data and general features specified in the previous pages.



DANGER

**Accessories and spare parts for installation and service procedures are to be supplied by the Manufacturer.
Should non original accessories and spare parts be employed, boiler proper performance is not guaranteed.**

3.1.1 Packaging

Boiler is shipped in a sturdy cardboard box.

Remove boiler from cardboard box and check its integrity.

The packing materials can be recycled. Disposal must be managed via appropriate waste collection sites.

Keep packaging out of reach of children, as it may be dangerous.

The manufacturer shall not be held responsible in case of damage to people, animals, or property due to failure to follow the above mentioned instructions.

Packaging includes one plastic bag containing:

- boiler installation, use and maintenance manual;
- the template for mounting the boiler on a wall (see Fig. 9 Paper template).
- 2 screws and relevant wall blocks for fixing the boiler to the wall;
- a corrugated pipe for condensate discharge
- water heater temperature probe (KRB model, only)

3.2 Choosing where to install the boiler

The following must be taken into account when choosing where to install the boiler:

- indications contained in paragraph *Air intake and flue gas venting system* on page 39 and its sub-paragraphs.
- check the wall for sturdiness, avoiding weak areas.
- do not install the boiler over appliances which may affect boiler operation (e.g. cookers, which produce steam and grease, washing machines etc.).
- do not install boilers in locations with a corrosive or very dusty atmosphere, such as hairdresser salons, laundries etc., as this may severely reduce the lifespan of the components of the boiler.

3.3 Positioning the boiler

Each boiler is supplied with a paper template, found inside the packaging (see Fig. 9 Paper template).

The template allows you to ensure that the pipes connected to the CH system, the DHW system and the gas mains, and the air intake/flue gas venting ducts are all laid out correctly during the realisation of the water system and before installation of the boiler.

This template is made of heavy-duty paper and must be fixed, with the help of a level, onto the wall where the boiler is to be mounted.

The template provides all the indications required to drill the boiler mounting holes to the wall, procedure which is done using two screws and wall blocks.

The lower area of the template shows where to mark the exact point at which the couplings are to be positioned for boiler connection to the gas supply pipe, cold water mains supply pipe, hot water outlet, CH flow and return pipes.

The upper area of the template shows where air intake and flue gas ducts are to be positioned.



DANGER

Since the temperature of the walls on which the boiler is mounted and external temperature of coaxial air/flue gas system do not exceed 60°C, no minimum distance from flammable walls is to be accounted for.

For boilers with split air intake and flue gas venting ducts, in the case of proximity with flammable walls and passages through walls, apply insulating material between the wall and the flue gas venting duct.

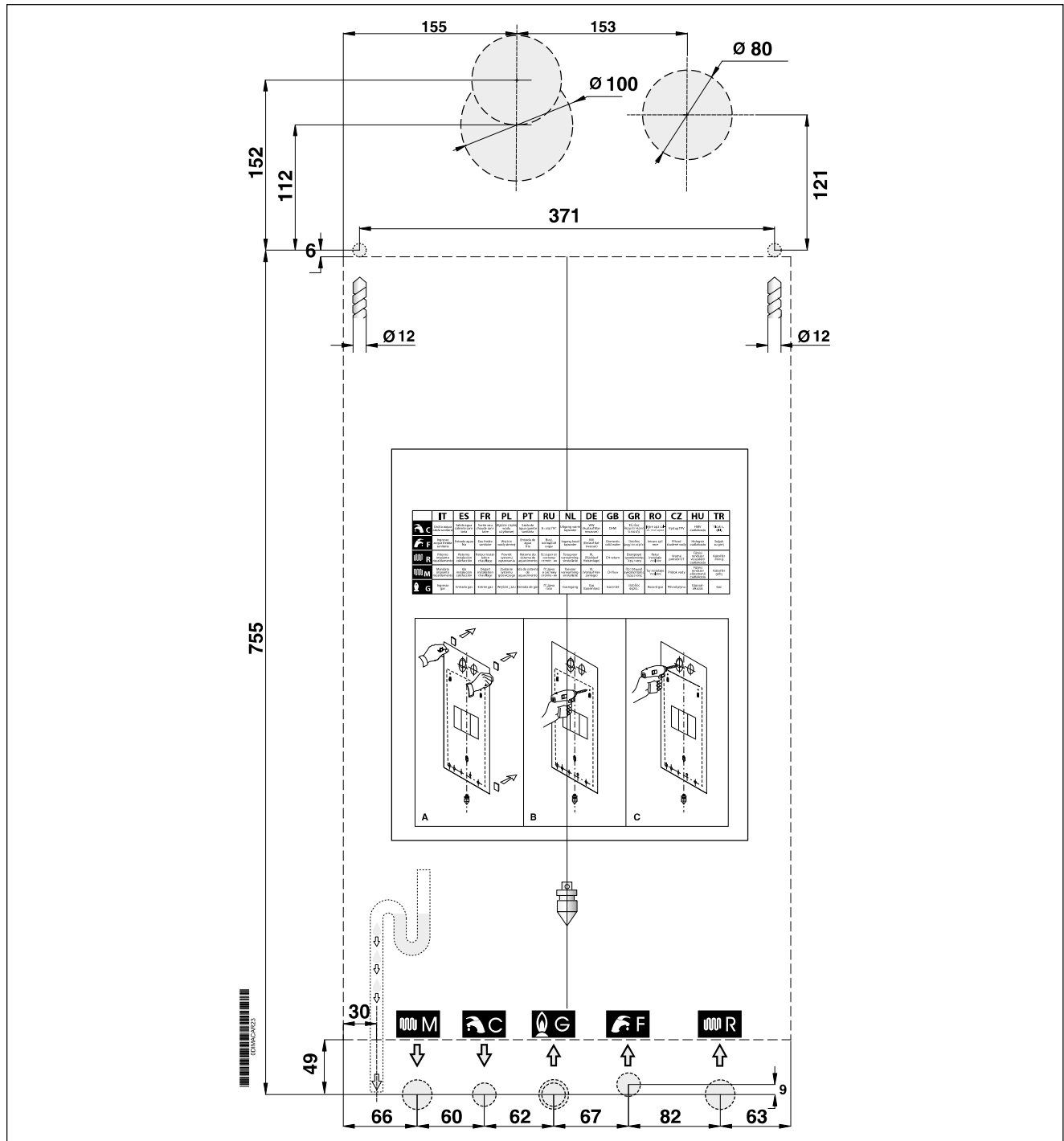

Fig. 9 Paper template

3.4 Installing the boiler



DANGER

Before connecting the boiler to CH and DHW networks, clean the pipes carefully.

Before commissioning a NEW system, clean it to remove any metal chips due to machining and welding, and any oil and grease that might negatively affect boiler operation or even damage it in case they get inside it.

Before commissioning a RECONDITIONED system (where radiators have been added, the boiler has been replaced, etc.) thoroughly clean it to remove any sludge and residues.

Clean the system using standard non acid products, available on the market.

Do not use solvents as they could damage system components.

Furthermore, in the central heating system (either new or reconditioned), it is always advisable to add to water a suitable percentage of corrosion protectants for multi-metal systems that will create a protective film onto all internal surfaces.

The manufacturer shall not be held responsible in case of damage to people, animals, or property due to failure to follow the above mentioned instructions.



DANGER

For all boiler installation types, it is necessary to install a filter which can be inspected (Y-shaped type) with Ø 0.4mm-mesh, on the return pipe before the boiler.

In order to install the boiler proceed as follows:

- Affix the template to the wall.
- Check that 1 cm to the right and 1 cm to the left of the boiler is left for casing removal.
- Drill two 12 mm diameter holes in the wall for the wall plugs, insert the wall plugs supplied with the boiler and apply and tighten the screws.
- If necessary, provide holes in the wall to allow air intake and/or flue gas venting ducts to pass through it;
- With reference to the lower part of the template, position the fittings for the connection of:
 - » gas supply pipe **G**;
 - » cold water supply pipe (KC/KR) or return from water heater (KRB) **F**;
 - » DHW outlet (KC) or flow to water heater (KRB) **C**;
 - » CH flow **M**;
 - » CH return **R**.
- Provide a condensate drain and an outlet for the 3-bar safety valve.
- Hook the boiler to the previously fitted screws.
- Connect the boiler to the feed pipes (see *Hydraulic connections* on page 46).
- Connect the boiler to an outlet for the 3-bar safety valve.
- Connect the boiler to pipe for condensate drain.
- Connect the boiler to the air intake and flue gas venting system (see *Air intake and flue gas venting system* on page 39).
- connect power supply, ambient thermostat (when available) and other available accessories (refer to the following paragraphs).

3.5 Boiler room ventilation

The boiler has sealed combustion chamber. Combustion air is not drawn from boiler room, therefore no specific recommendations need to be applied concerning the boiler room or openings and ventilation provided to the boiler room.



DANGER

the boiler must be installed in a room that is compliant with the legislation and standards in force in the country of installation, which are herein considered as entirely transcribed.

3.6 Air intake and flue gas venting system

Flue gas discharge into the atmosphere and air intake/flue gas venting systems must comply with applicable laws and standards in the country of installation that are considered as fully transcribed herein.



DANGER

The boiler is equipped with a safety device for flue gas exhaustion check.

It is strictly forbidden to tamper with and/or prevent operation of such safety device.

Should an air/flue gas system malfunction occur, the device will shut-down the boiler by interrupting the gas supply to the boiler and the LCD will display the E03 code.

In this case it is necessary to have safety device, boiler and the air intake/flue gas venting ducts promptly checked by a service centre or a qualified service engineer.

In case of repeated stops, it is necessary to have safety device, boiler and the air intake/flue gas venting ducts checked by a service centre or a qualified service engineer.

After each operation on the safety device or the air suction/flue gas exhaust system, it is necessary to perform a functional test of the boiler.

In case it is necessary to replace the safety device use only original spare parts supplied by the Manufacturer.

To reset the combustion gas exhaust control device operation it is necessary to press "Reset".



DANGER

For the air intake/flue gas venting systems, specific, manufacturer approved, condensate acid-resistant pipes and systems must be used, suitable for condensing boilers.



DANGER

Flue gas venting pipes are to be installed tilted toward the boiler so that condensate runs toward the combustion chamber, which is designed for condensate collection and drainage.

Should the above procedure not be possible, it is necessary to install, in condensate stagnation areas, devices designed for condensate collection and conveying to the condensate drain system.

It is necessary to avoid formation of condensate stagnation areas in the flue gas venting system, with the exception of the condensate trap possibly connected to the venting system itself.

The manufacturer cannot be held responsible for any damage caused by inappropriate boiler installation or operation, modification to the boiler, or due to non-observance of the instructions provided by the manufacturer or of legislation and standards applicable for the materials installed.

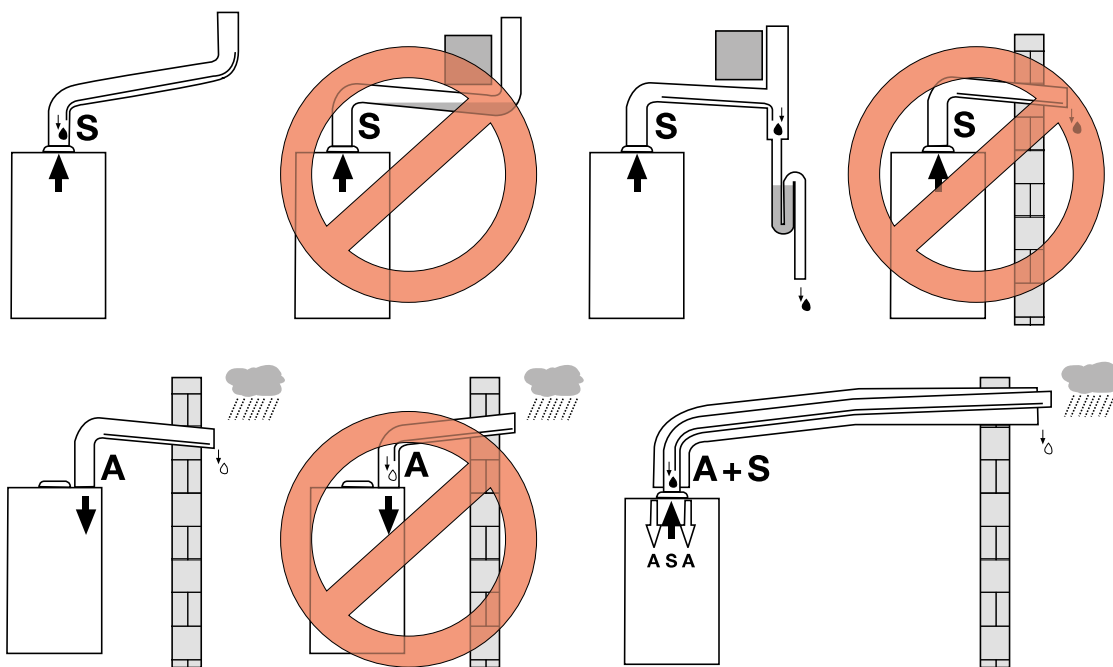

Fig. 10 Installation examples

KEY

- A** Air intake
- S** Flue gas vent
- ☘ Condensate
- ☔ Rain

3.6.1 Possible configuration of air intake and flue gas venting ducts

Type B23

Boiler intended for connection to an existing flue system external to the boiler room.

Combustion air is taken directly from the boiler room itself while flue gas is conveyed to the outside.

The boiler is not to be fitted with anti-wind gust device; it has to be equipped with a fan mounted before the combustion chamber/heat exchanger.

Type B53

Boiler intended for connection, via an independent duct, to the flue gas venting terminal.

Combustion air is taken directly from the boiler room itself while flue gas is conveyed to the outside.

The boiler is not to be fitted with anti-wind gust device; it has to be equipped with a fan mounted before the combustion chamber/heat exchanger.

Type C13

Boiler intended for connection to horizontal outlet and intake ducts connected to the outside by means of coaxial or split ducts.

The minimum distance between the air intake duct and the flue gas venting duct must be at least 250 mm, whereas both terminals must be contained within a square measuring 500 x 500 mm.

The boiler is to be equipped with a fan mounted before the combustion chamber/heat exchanger.

Type C33

Boiler intended for connection to vertical outlet and intake ducts connected to the outside by means of coaxial or split ducts.

The minimum distance between the air intake duct and the flue gas venting duct must be at least 250 mm, whereas both terminals must be contained within a square measuring 500 x 500 mm.

The boiler is to be equipped with a fan mounted before the combustion chamber/heat exchanger.

Type C43

Boiler intended for connection to collective chimney pipe system that includes two ducts, air intake and flue gas exhaustion. These ducts may be coaxial or split.

The chimney must be compliant with applicable legislation and standards.

The boiler is to be equipped with a fan mounted before the combustion chamber/heat exchanger.

Type C53

Boiler with separate pipes for combustion air intake and flue gas evacuation.

These flues may discharge in areas at a different pressure.

The terminals may not face each other from opposed walls.

The boiler is to be equipped with a fan mounted before the combustion chamber/heat exchanger.

Type C83

Boiler intended to be connected to combustion air terminal and to a single flue gas terminal or collective chimney.

The chimney must be compliant with applicable legislation and standards.

The boiler is to be equipped with a fan mounted before the combustion chamber/heat exchanger.

3.6.2 Ø 100/60 mm and Ø 125/80 mm air/flue gas coaxial duct system



WARNING

The information given above is with reference to air intake/flue gas venting ducts made from smooth, rigid pipes approved and supplied by the manufacturer.

C13 installation type

KC-KR-KRB 12

- Minimum permissible length of horizontal coaxial pipes is 1 meter.
- Maximum permissible length of Ø100/60 mm horizontal coaxial pipes is 9 meters.
- Maximum permissible length of Ø125/80 mm horizontal coaxial pipes is 13.5 meters.
- For each additional 1 meter of straight pipe maximum permissible length is to be reduced by 1 meter.
- For each additional 90° elbow, maximum permissible length is to be reduced by 1 meter.
- For each additional 45° elbow, maximum permissible length is to be reduced by 0.5 meter.
- The wall terminal reduces maximum permissible length by 1.5 meters.
- The flow resistance of the first elbow shall not be taken into account to calculate maximum permissible length.
- The air intake duct is to be tilted down by 1% toward its exit, in order to avoid rain water to enter it.

KC-KR-KRB 24

- Minimum permissible length of horizontal coaxial pipes is 1 meter.
- Maximum permissible length of Ø100/60 mm horizontal coaxial pipes is 10 meters.
- Maximum permissible length of Ø125/80 mm horizontal coaxial pipes is 14.5 meters.
- For each additional 1 meter of straight pipe maximum permissible length is to be reduced by 1 meter.
- For each additional 90° elbow, maximum permissible length is to be reduced by 1 meter.
- For each additional 45° elbow, maximum permissible length is to be reduced by 0.5 meter.
- The wall terminal reduces maximum permissible length by 1.5 meters.
- The flow resistance of the first elbow shall not be taken into account to calculate maximum permissible length.
- The air intake duct is to be tilted down by 1% toward its exit, in order to avoid rain water to enter it.

KC-KR-KRB 28

- Minimum permissible length of horizontal coaxial pipes is 1 meter.
- Maximum permissible length of Ø100/60 mm horizontal coaxial pipes is 9 meters, first curve included.
- Maximum permissible length of Ø125/80 mm horizontal coaxial pipes is 13.5 meters, first curve included.
- For each additional 1 meter of straight pipe maximum permissible length is to be reduced by 1 meter.
- For each additional 90° elbow, maximum permissible length is to be reduced by 1 meter.
- For each additional 45° elbow, maximum permissible length is to be reduced by 0.5 meter.
- The wall terminal reduces maximum permissible length by 1.5 meters.
- The flow resistance of the first elbow shall not be taken into account to calculate maximum permissible length.
- The air intake duct is to be tilted down by 1% toward its exit, in order to avoid rain water to enter it.

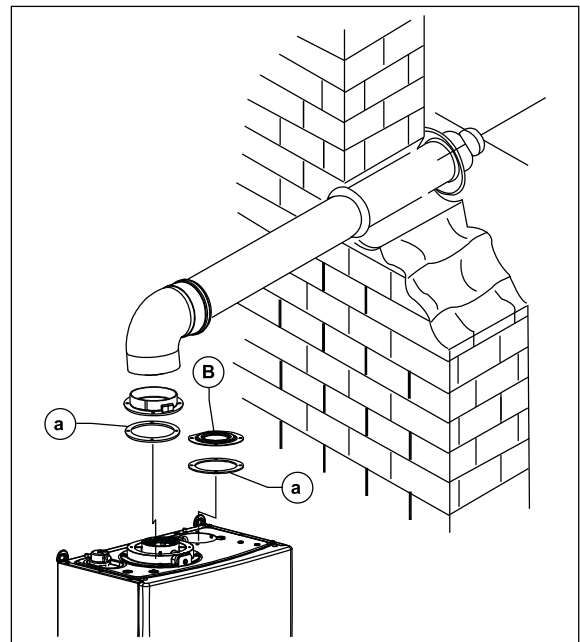

Fig. 11 Type C13 - C33 coaxial ducts

- A. Gasket
- B. Blanking cap

C33 installation type

KC-KR-KRB 12

- Minimum permissible length of horizontal coaxial pipes is 1 meter.
- Maximum permissible length of Ø100/60 mm horizontal coaxial pipes is 9 meters.
- Maximum permissible length of Ø125/80 mm horizontal coaxial pipes is 13.5 meters.
- For each additional 1 meter of straight pipe maximum permissible length is to be reduced by 1 meter.
- For each additional 90° elbow, maximum permissible length is to be reduced by 1 meter.
- For each additional 45° elbow, maximum permissible length is to be reduced by 0.5 meter.
- The roof vent terminal reduces maximum permissible length by 1.5 meters.

KC-KR-KRB 24

- Minimum permissible length of horizontal coaxial pipes is 1 meter.
- Maximum permissible length of Ø100/60 mm horizontal coaxial pipes is 10 meters.
- Maximum permissible length of Ø125/80 mm horizontal coaxial pipes is 14.5 meters.
- For each additional 1 meter of straight pipe maximum permissible length is to be reduced by 1 meter.
- For each additional 90° elbow, maximum permissible length is to be reduced by 1 meter.
- For each additional 45° elbow, maximum permissible length is to be reduced by 0.5 meter.
- The roof vent terminal reduces maximum permissible length by 1.5 meters.

KC-KR-KRB 28

- Minimum permissible length of horizontal coaxial pipes is 1 meter.
- Maximum permissible length of Ø100/60 mm horizontal coaxial pipes is 9 meters, first curve included.
- Maximum permissible length of Ø125/80 mm horizontal coaxial pipes is 13.5 meters, first curve included.
- For each additional 1 meter of straight pipe maximum permissible length is to be reduced by 1 meter.
- For each additional 90° elbow, maximum permissible length is to be reduced by 1 meter.
- For each additional 45° elbow, maximum permissible length is to be reduced by 0.5 meter.
- The roof vent terminal reduces maximum permissible length by 1.5 meters.

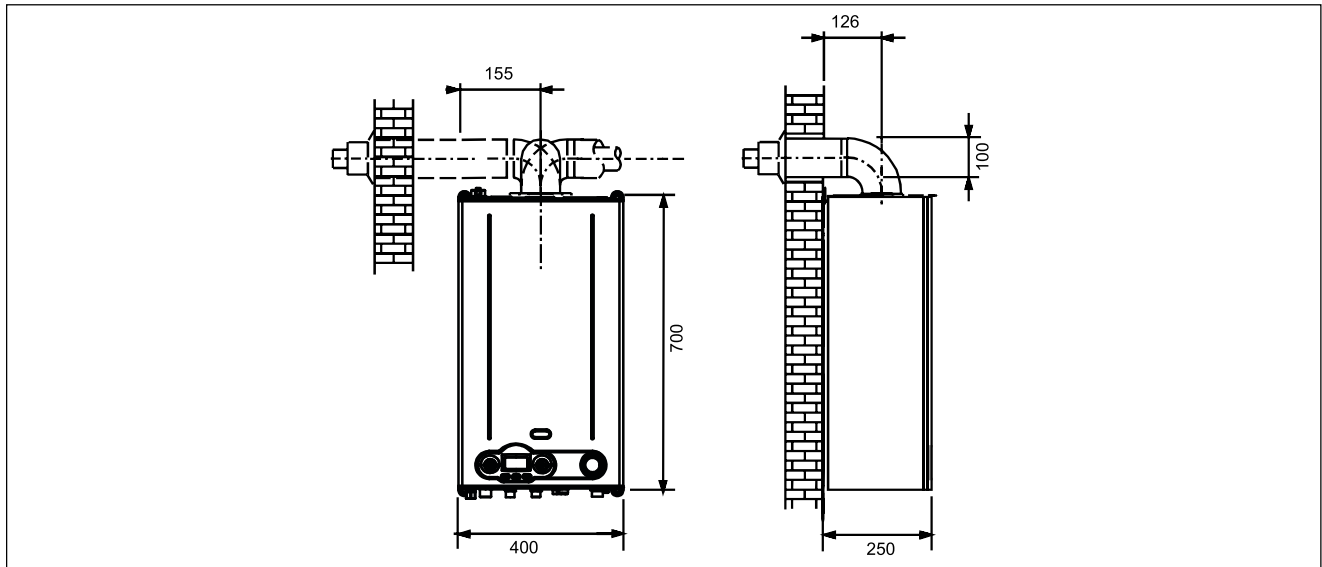

Fig. 12 Type C12 - C33 coaxial pipes dimensione

3.6.3 Air intake and flue gas venting via 80 mm split pipes



WARNING

The information given above is with reference to air intake/flue gas venting ducts made from smooth, rigid pipes approved and supplied by the manufacturer.

Installation types C43 - C53 - C83

KC-KR-KRB 12

- Minimum permissible length of air intake pipe is 1 meter.
- Minimum permissible length of flue gas venting pipe is 1 meter.
- Maximum permissible length of intake/flue gas venting pipes is 152 meters (combined length of air intake and flue gas venting pipe).
- For each additional 1 meter of straight pipe maximum permissible length is to be reduced by 1 meter.
- For each additional 90° elbow, maximum permissible length is to be reduced by 1 meter.
- For each additional 45° elbow, maximum permissible length is to be reduced by 0.5 meter.
- The roof terminal reduces maximum permissible length by 5 meters.
- The wall terminal reduces maximum permissible length by 4.5 meters.

KC-KR-KRB 24

- Minimum permissible length of air intake pipe is 1 meter.
- Minimum permissible length of flue gas venting pipe is 1 meter.
- Maximum permissible length of intake/flue gas venting pipes is 84 meters (combined length of air intake and flue gas venting pipe).
- For each additional 1 meter of straight pipe maximum permissible length is to be reduced by 1 meter.
- For each additional 90° elbow, maximum permissible length is to be reduced by 1 meter.
- For each additional 45° elbow, maximum permissible length is to be reduced by 0.5 meter.
- The roof terminal reduces maximum permissible length by 5.5 meters.
- The wall terminal reduces maximum permissible length by 5 meters.

KC-KR-KRB 28

- Minimum permissible length of air intake pipe is 1 meter.
- Minimum permissible length of flue gas venting pipe is 1 meter.
- Maximum permissible length of intake/flue gas venting pipes is 91 meters (combined length of air intake and flue gas venting pipe).
- For each additional 1 meter of straight pipe maximum permissible length is to be reduced by 1 meter.
- For each additional 90° elbow, maximum permissible length is to be reduced by 1.5 meter.
- For each additional 45° elbow, maximum permissible length is to be reduced by 1 meter.
- The roof terminal reduces maximum permissible length by 5.5 meters.
- The wall terminal reduces maximum permissible length by 5.5 meters.

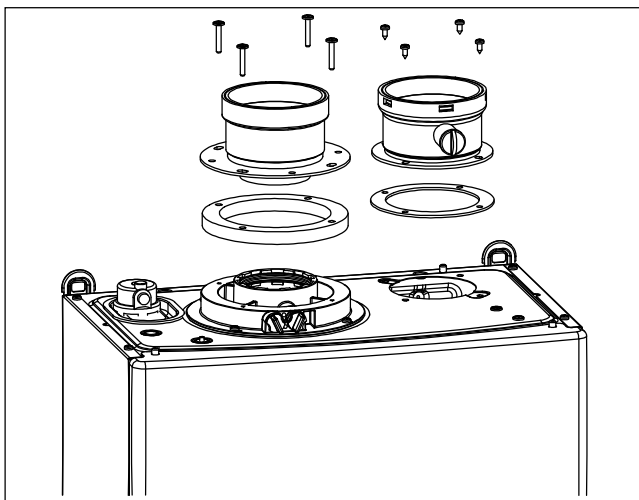

Fig. 13 Split pipe kit 0KITSDOP00

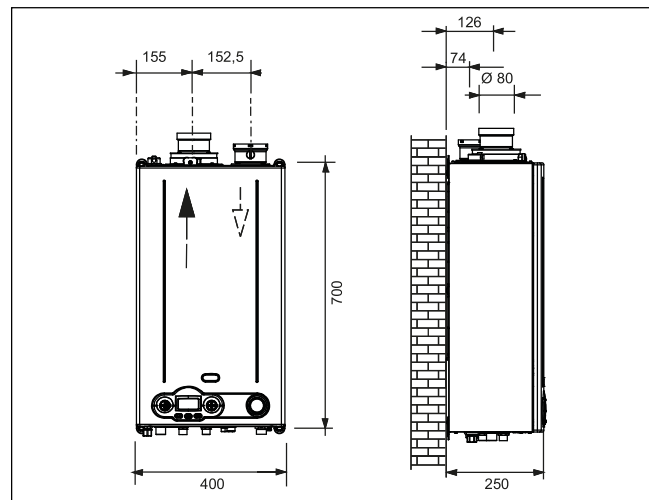

Fig. 14 Dimensions for split pipes

3.6.4 Air intake and flue gas venting via 60 mm split pipes



WARNING

The information given above is with reference to air intake/flue gas venting ducts made from smooth, rigid pipes approved and supplied by the manufacturer.

Installation types C43 - C53 - C83

KC-KR-KRB 12-24-28

- Minimum permissible length of air intake pipe is 1 meter.
- Minimum permissible length of flue gas venting pipe is 1 meter.
- Maximum permissible length of air intake/flue gas venting pipes is 39 metres for model KC-KR-KRB 12 and 23 metres for model KC-KR-KRB 24-28 (combined length of air intake and flue gas venting pipe length).
- For each additional 1 meter of straight pipe maximum permissible length is to be reduced by 1 meter.
- For each additional 90° elbow, maximum permissible length is to be reduced by 1 meter.
- For each additional 45° elbow, maximum permissible length is to be reduced by 0.5 meter.
- The wall terminal reduces maximum permissible length by 4 metres for the KC-KR-KRB 12 model and by 4.5 metres for KC-KR-KRB 24-28 models.

3.7 Checking combustion efficiency

3.7.1 Flue cleaning function

- The boiler features a flue cleaning function which must be used to measure combustion efficiency during operation and to adjust the burner.
- To activate the flue cleaning function, press and hold the buttons “Info” and “Reset” simultaneously for 5 seconds. The flow temperature and the  symbol are shown on the LCD.
- When the flue cleaning function is activated with the boiler in WINTER or SUMMER mode, the boiler performs the ignition sequence and then operates at a fixed power output predetermined by the parameter **P7** (maximum CH output).
- To exit the flue cleaning mode, press “Reset” or wait 15 minutes.

3.7.2 Measurement procedure

Regulatory document: UNI 10389, UNI 10642.

The boiler is equipped with a tower allowing for air intake/flue gas venting pipe connection (see Fig. 15 Plugs position and Fig. 16 Hole position).

The tower is designed with two pre-arranged openings directly accessing air and flue gas ducts (see Fig. 16 Hole position).

Remove caps **A** and **B** from the pre-arranged openings on the tower, before starting combustion checking procedure (see Fig. 15 Plugs position).

In order to verify combustion efficiency the following measurements must be implemented:

- assess combustion air from opening **1** (see Fig. 16 Hole position).
- assess flue gas temperature and CO₂ from opening **2** (see Fig. 16 Hole position).
- Allow boiler to reach working temperature before taking any measurement.

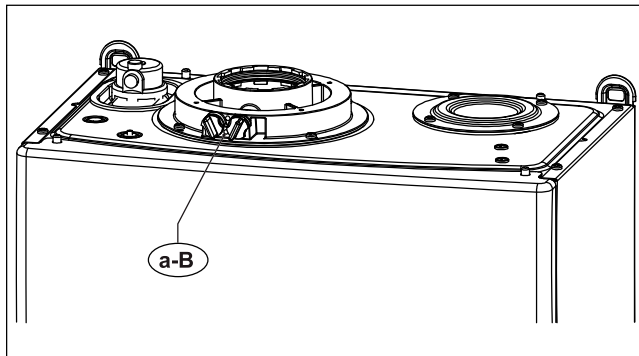

Fig. 15 Plugs position

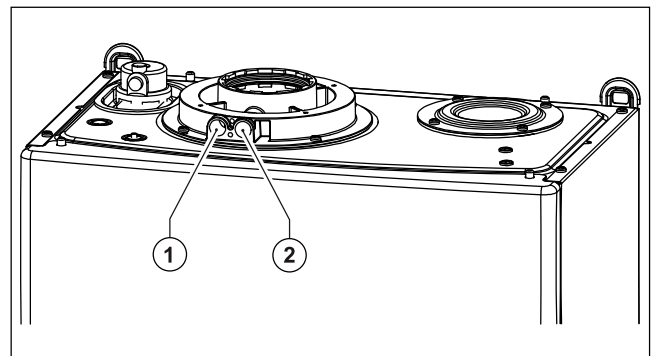

Fig. 16 Hole position

3.8 Connection to gas mains

Cross-section gas pipe size must be chosen depending on its length, layout pattern, gas flow rate.
Gas supply pipe cross-section must be equal or greater than boiler gas pipe.



DANGER

Comply with installation standards enforced in the country where the boiler is installed which are considered as fully transcribed in this booklet.

Remember that before operating an indoor gas distribution system and before connecting it to a meter, it must be checked for leaks.

If some system parts are not visible, the leak test is to be carried out before the pipes are covered.

Leak test is NOT to be carried out employing flammable gas: use air or nitrogen for this purpose.

Once gas is in the pipes, leak test by a naked flame is forbidden; use specific products available on the market.

When connecting the boiler to gas supply network, it is COMPULSORY to install an appropriately sized gasket (A) made from suitable material (see Fig. 17 Connection to gas mains).

The boiler gas inlet coupling is NOT suitable for hemp, teflon tape or similarly made gaskets.

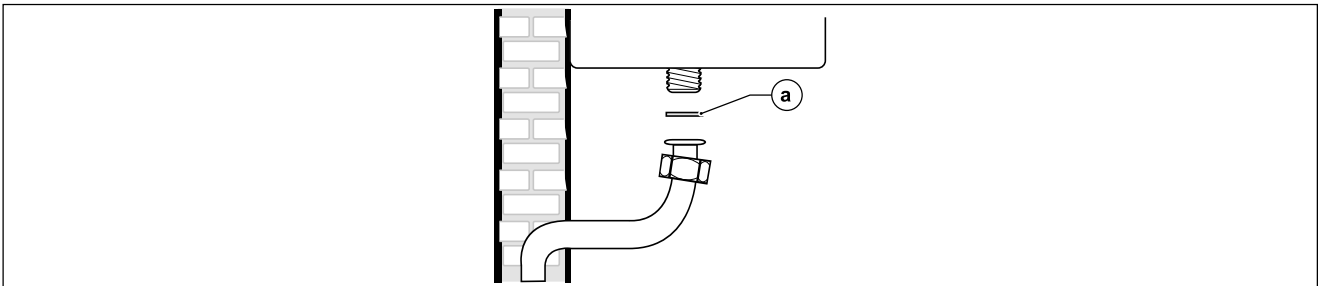

Fig. 17 Connection to gas mains

3.9 Hydraulic connections

3.9.1 Central heating

Prior to installing the boiler, the hydraulic system is to be cleaned in order to remove impurities; they could be present in system components and damage the pump and the heat exchanger.

The CH outlet and return pipes must be connected to the respective 3/4" connectors **M** and **R** on the boiler (see Fig. 9 Paper template).

When calculating the cross section of CH system pipes, bear in mind load losses induced by radiators, thermostatic valves, radiator gate valves, and the configuration of the system itself.



WARNING

It is advisable to convey the discharge flow of boiler safety valve to the sewer system. Should the above precaution not be implemented and the safety valve be activated, boiler room flooding may occur.

The manufacturer shall not be held responsible in case of damage to people, animals, or property due to failure to follow the above mentioned instructions.

3.9.2 DHW

Prior to installing the boiler, the hydraulic system is to be cleaned in order to remove impurities; they could be present in system components and damage the pump and the heat exchanger.

Model KC

Cold water inlet and DHW outlet shall be connected to the boiler through the dedicated 1/2" **F** and **C** fittings.
Hardness of water supplied to the boiler may increase the plate heat exchanger cleaning/replacement intervals.

Model KR

Cold water inlet shall be connected to the boiler through the special 1/2" fitting **C**.

Model KRB

Return from the water heater (RB) and flow to water heater (MB) must be connected to the respective 1/2" connectors **F** and **C** on the boiler



WARNING

Depending on the hardness of the mains water supply, ascertain whether or not to install appropriate domestic water treatment systems using water treatment products suitable for drinking water and compliant with the regulations and standards in force in the country of installation.

Water treatment is always advisable when water supplied to the boiler is more than 20°F hard.

Water supplied by commonly marketed water softeners, due to PH level induced in water, may not be compatible with some components in the system.

3.9.3 Condensate drain

Comply with condensate drain laws and standards applicable in the country of installation, which are considered herein integrally transcribed. Unless forbidden, the condensate produced by combustion is to be routed via the condensate drain through a discharge system connected to the domestic sewer, which due to its basicity, counteracts flue gas condensate acidity. In order to avoid domestic sewer odour to reach the premises, it is advisable to install an appropriate device between the discharge system and the domestic sewer. The condensate drain system and the domestic discharge system is to be made of an adequate, condensate-resistant material.

Condensate drain system must be connected to specific fitting (A) in the boiler (see Fig. 18 Condensate drain).

It is strictly forbidden to connect condensate drain system in trap inspection point (B).



WARNING

The manufacturer shall not be held responsible in case of damage to people, animals, or property due to failure to follow the above mentioned instructions.

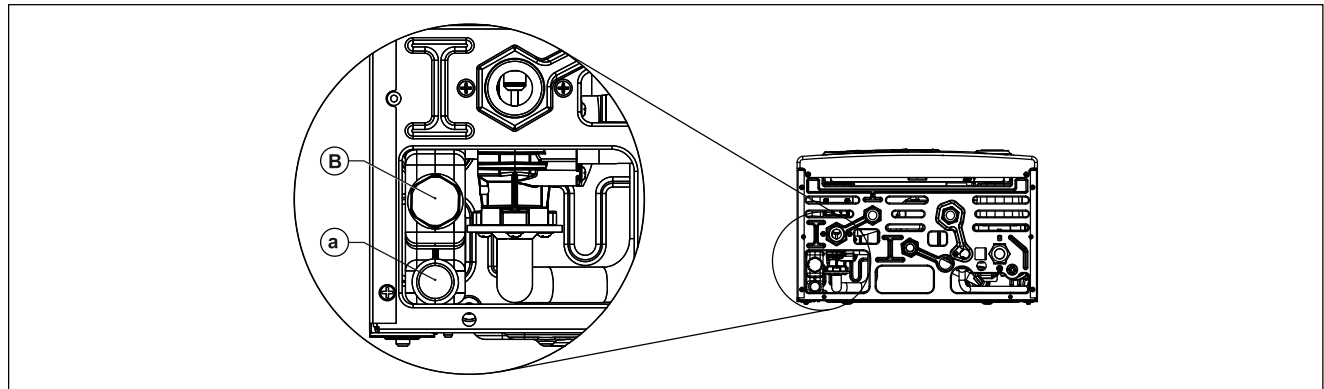

Fig. 18 Condensate drain

3.10 Connection to electrical mains

The boiler is supplied with a three-poled power cable, already connected to the electronic board and it is provided with a safety clamp. The boiler is to be connected to a 230V-50Hz electrical power supply.

When connecting it to power mains, follow correct phase / neutral polarity sequence.

Installation standards must be complied with and they are herein considered as entirely transcribed.

An easily accessible two-poled switch, with a minimum 3 mm distance between contacts, is to be installed ahead of the boiler. The switch is to allow power supply cut-off in order to safely perform maintenance and service procedures.

Power supply to the boiler must be fitted with a residual-current circuit breaker having suitable disconnection capacity. Electric power supply must be properly earthed.

The above mentioned safety measure must be verified. If in doubt, ask a qualified technician to thoroughly check the power network.



WARNING

The manufacturer cannot be held responsible for any damage caused by failure to earth the system correctly: gas, water, or CH system pipes are not suitable for grounding power networks.

3.11 Connection to ambient thermostat (optional)

The boiler is designed to be connected to an ambient thermostat (optional, not compulsory).

Ambient thermostat contacts must be properly sized in compliance with a load of 5 mA at 24 Vdc.

The ambient thermostat cables must be connected to terminals (1) and (2) of the electronic board (see *Wiring diagrams*) after eliminating the jumper supplied as a standard with the boiler.

The ambient thermostat cables are not to be grouped together in the same sheath as power mains supply cables.

3.12 Installation and operation with Open Therm Remote Control (optional)



WARNING

Only use original Remote Control Units supplied by the manufacturer.

The correct operation of the Remote Control itself and of the boiler is not guaranteed if non original Remote Control units not supplied by the manufacturer are used.

The boiler may be connected to an Open Therm Remote Control (non-compulsory optional accessory supplied by manufacturer).

The Remote Control must only be installed by qualified personnel.

To install the Remote Control, refer to the instructions provided with the Remote Control itself.

The Remote Control must be installed on an indoor wall at a height of approximately 1.5 m from the floor and in a suitable location for measuring ambient temperature: do not install in recess or corners, behind doors or curtains, and install away from heat sources, direct sunlight, air draughts and water sprays.

The Remote Control cables must be connected to terminals 3 and 4 of the electronic board.

The Remote Control connector is protected against inverted polarity, and the connections may be inverted.



WARNING

Do not connect the remote control to mains electrical power 230 V ~ 50 Hz.

The remote control wiring must not be grouped together in the same sheath as the power cables: if the cables are sheathed together, electrical interference from the power cables may compromise the functions of the Remote Control;

For complete instructions on how to program the Remote Control, refer to the instruction manual included in the Remote Control kit. Board and Remote Control communicate in each operating mode: OFF, SUMMER, WINTER, CH ONLY.

Boiler display layout corresponds to the setting made from the Remote Control, as for the operating mode.

The remote control may be used to view and set a number of special parameters denominated **TSP** parameters and reserved solely for qualified technicians.

TSP0 parameter sets default data table and restores all factory settings, cancelling all preceding modifications on single parameters.

If a single parameter is found to be incorrect, the value given in the default value table is restored.

If the user attempts to set a value not within the permissible range for the parameter, the new value is rejected and the existing value is maintained.

3.12.1 Selecting the operating range in heating mode

Heating water temperature adjustment range depends on the selected operating range.:

- **standard range:** from 20°C to 78°C (pressing **CH +/-**);
- **reduced range:** from 20°C to 45°C (pressing **CH +/-**).

The standard range is active with curves **P10** ≥ 1 , while the reduced range is active with curves **P10** < 1 .

The two ranges can also be selected even with the external probe disconnected.

The waiting time between one boiler ignition and the following one, used to prevent boiler frequent turning on and off is 4 minutes for both ranges, and can be edited with the parameter **P11**.

If system water temperature decreases below a certain value, the waiting time is reset and the boiler re-ignited, as shown in the following table:

Selected range	Re-ignition temperature
Standard range	$< 40^{\circ}\text{C}$ (P27)
Reduced range	$< 20^{\circ}\text{C}$

Tab. 15 Boiler re-ignition temperature

Operation range selection is to be implemented by a installer or a qualified Service Centre.

3.12.2 Installation of the (optional) external probe and sliding temperature operation

The boiler can be connected to an (optional) external temperature probe (optional, provided by the manufacturer) for sliding temperature operation.



WARNING

Only original external temperature probes supplied by the manufacturer must be used.

If non-original external temperature probes are used, correct operation of the boiler and external probe cannot be guaranteed.

The external temperature probe must be connected by means of a double insulated wire, minimum cross-section 0.35 sq.mm.

The external probe must be connected to terminals (5) and (6) of boiler electronic board.



WARNING

The temperature probe cables must NOT be routed together with power cables.

The temperature probe must be installed on an outside wall facing NORTH - NORTH EAST, in a position protected from weather.

Do not install near a window, ventilation openings or sources of heat.

The external temperature probe automatically modifies the CH flow temperature in relation to:

- Measured external temperature.
- Selected thermoregulation curve.
- Selected fictitious ambient temperature.

The thermoregulation curve is selected via parameter **P10**.

During adjustment, the set value will flash on LCD. Such value can also be read as parameter **TSP10** on the Remote Control (when installed).

The relation between parameter **TSP10** setting and the thermoregulation curve coefficient is the following:

- coefficient = TSP10 value / 84.67

The fictitious ambient temperature is set using **CH +/-** buttons that, with external probe installed, no longer work to set the heating water temperature (see *Operation with external probe (optional)* on page 13).

Through boiler parameter **P30** it is possible to display the value of the outside temperature detected by the external probe.

The figure shows the curves for a fictitious ambient temperature of 20°C. Parameter **P10** allows selecting the curve value shown (see Fig. 19 Thermoregulation curves).

If fictitious ambient temperature value is edited on boiler display, the curves shift up or down, respectively, by the same amount.

With a fictitious ambient temperature setting of 20°C, for example, if you select the curve corresponding to parameter 1 and the outdoor temperature is -4°C, the CH flow temperature will be 50°C.

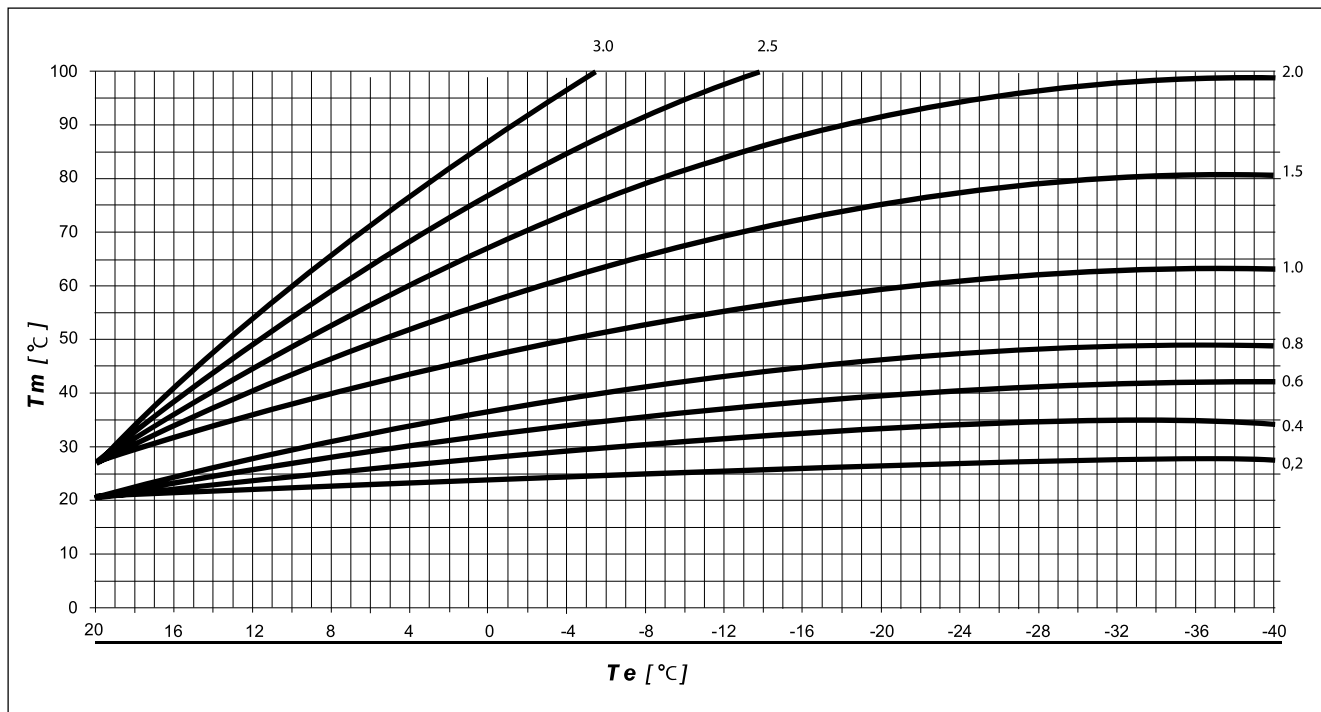

Fig. 19 Thermoregulation curves

Tm indicates flow water temperature in °C

Te indicates external temperature in °C

3.13 TSP parameters

The boiler operation is controlled by several parameters.

To modify parameters press buttons **Reset** and **- CH** together for 3 seconds.

Scroll through the parameters by pressing **CH +/-** buttons.

As soon as you reach the one to be modified, press **ok**.

The  symbol turns on to indicate that you can edit the parameter value.

The parameter value can be edited using **CH +/-** buttons.

To confirm modification press **Ok**.

To exit the parameter editing mode press button **Reset**.

Parameter	Settable values	Default values	Notes
P0 - TSP0 Boiler power selection	0 ÷ 5	According to the model	0 = 12 kW methane; 1 = 24 kW methane; 2 = 28 kW methane; 3 = 24 kW propane; 4 = 28 kW propane; 5 = 12 kW propane
P3 - TSP3 Boiler type selection	1 ÷ 3	According to the model	1 = combined instantaneous; 2 = heating only; 3 = with water heater
P4 - TSP4 Fan speed at burner maximum output	TSP5 ÷ 250 Hz	According to the model	187 = 12 kW methane; 181 = 12 kW propane; 199 = 24 kW methane; 192 = 24 kW propane; 201 = 28 kW methane; 198 = 28 kW propane
P5 - TSP5 Fan speed at burner minimum output	25 - 120 Hz	According to the model	39 = 12 kW; 42 = 24 kW; 40 = 28 kW
P6 - TSP6 Fan speed at ignition power	25 - 160 Hz	According to the model	48 = 12 kW; 58 = 24 kW; 60 = 28 kW
P7 - TSP7 Fan speed at heating maximum output	10 ÷ 100%	According to the model	75 = 12 kW methane; 74 = 12 kW propane; 88 = 24 and 28 kW
P8 - TSP8 Negative ramp start minimum speed	P5 ÷ P6	According to the model	56 = 12 and 24 kW; 60 = 28 kW
P9 - TSP9 Negative ramp time	0 ÷ 30 (1 = 10 sec.)	According to the model	18 = 12 and 24 kW; 25 = 28 kW
P10 - TSP10 Heating output curves	0 ÷ 3	1.5	-
P11 - TSP11 Heating thermostat timing	0 ÷ 10 min.	4	-
P12 - TSP12 CH power rising ramp timer	0 ÷ 10 min.	1	-
P13 - TSP13 Timer for CH post-circulation, freeze protection and flue cleaning function	30 ÷ 180 sec.	30	-
P15 - TSP15 Water hammer protection delay, configurable	0 ÷ 3 sec.	0	-

Tab. 16 Limits to be set for TSP parameters and default values in relation to boiler type (TSP0) - I

Parameter	Settable values	Default values	Notes
P16 - TSP16 Ambient thermostat/remote control reading delay	0 ÷ 199 sec.	0	-
P17 - TSP17 Multifunction relay setting	0, 1, 3	0	0 = shut-down and malfunction; 1 = ambient thermostat 1 request/Remote control; 2 = solar; 3 = ambient thermostat 2 request
P27 - TSP27 Heating timer reset temperature	20 ÷ 78 °C	P10 < 1 (low temp.) = 20 °C; P10 > 1 (high temp.) = 40 °C	
P28 - TSP28 Hydraulic setting for management of deviating valve relay	0 ÷ 1	0	0 = recirculation pump and deviating valve
P29 - TSP29 Default parameter setting (except for P0, P1, P2, P17-P28)	0 ÷ 1	0	0 = user parameters; 1 = default parameters
P30 External temperature	-	-	only with external probe connected
P31 Flow temperature	-	-	-
P32 Nominal calculated flow temperature	-	-	only with external probe connected
P33 Set point of zone 2 flow temperature	-	-	only with at least one zone board connected
P34 Current zone 2 flow temperature	-	-	only with at least one zone board connected
P36 Set point of zone 3 flow temperature	-	-	only with two zone boards connected
P37 Current zone 3 flow temperature	-	-	only with two zone boards connected
P39 Set point of zone 4 flow temperature	-	-	only with three zone boards connected (optional)
P40 Current zone 4 flow temperature	-	-	only with three zone boards connected (optional)
P42 DHW plate exchanger temperature	-	-	only for KC models
P43 Boiler return temperature	-	-	-
P44 Water heater temperature (KR/KRB models)	-	-	only for KR/KRB models, with water heater probe connected
P45 Flue gas temperature	-	-	-

Tab. 17 Limits to be set for TSP parameters and default values in relation to boiler type (TSP0) - II

Parameter	Settable values	Default values	Notes
P51 Display of most recent boiler shutdown/fault	Fault code	-	-
P52 Display of second last boiler shutdown/fault	Fault code	-	-
P53 Display of third last boiler shutdown/fault	Fault code	-	-
P54 Display of fourth last boiler shutdown/fault	Fault code	-	-
P55 Display of fifth last boiler shutdown/fault	Fault code	-	-
P56 Number of faults since last reset	-	-	-
P57 Board use month displaying	-	-	-
P60 Number of additional boards connected	0 ÷ 3	0	-
P61 Remote control / room thermostats association	00 ÷ 02	00	00 = zone 2 remote control / zone 1 TA; 01 = zone 2 TA1 / zone 2 TA1; 02 = zone 2 TA / zone 1 remote control
P62 Selection of zone 2 curve	0 ÷ 3	0.6	only with zone board connected
P63 Zone 2 set-point (fictitious temp.)	15 ÷ 35 °C	20 °C	only with zone board connected
P66 Selection of zone 3 curve	0 ÷ 3	0.6	only with two zone boards connected
P67 Zone 3 set-point (fictitious temp.)	15 ÷ 35 °C	20 °C	only with two zone boards connected
P70 Selection of zone 4 curve	0 ÷ 3	0.6	only with three zone boards connected
P71 Zone 4 set-point (fictitious temp.)	15 ÷ 35 °C	20 °C	only with three zone boards connected
P74 Low temperature zone mixer valve opening time	0 ÷ 300 sec.	140 sec.	only with zone boards connected

Tab. 18 Limits to be set for TSP parameters and default values in relation to boiler type (TSP0) - III

Parameter	Settable values	Default values	Notes
P80 Multifunction relay forcing	0 ÷ 1	0	0 = standard function; 1 = relay energised
P81 Zone 2 pump relay forcing	0 ÷ 1	0	0 = standard function; 1 = relay energised
P82 Zone 2 mixing valve forcing	0 ÷ 2	0	0 = standard function; 1 = force opening; 2 = force closing
P84 Zone 3 pump relay forcing	0 ÷ 1	0	0 = standard function; 1 = relay energised
P85 Zone 3 mixing valve forcing	0 ÷ 2	0	0 = standard function; 1 = force opening; 2 = force closing
P87 Zone 4 pump relay forcing	0 ÷ 1	0	0 = standard function; 1 = relay energised
P88 Zone 4 mixing valve forcing	0 ÷ 2	0	0 = standard function; 1 = force opening; 2 = force closing
P95 P51 to P56 displaying shutdowns reset	-	-	-

Tab. 19 Limits to be set for TSP parameters and default values in relation to boiler type (TSP0) - IV

3.14 Filling the system

Once all boiler connections have been completed, CH system can be filled.

The procedure is to be cautiously carried out, following each step:

- Open the bleeding valves on all radiators and verify the boiler automatic valve operation.
- Gradually open the relevant filler cock, checking any automatic bleeding valves installed in the system properly work (see Fig. 2 Filler cock).
- Close all radiator bleeding valves as soon as water starts coming out.
- Check on pressure gauge that water pressure reaches the 1÷1.3 bar reading.
- Shut the filler cock and bleed any air out again, by opening the air bleeding valves on radiators.
- Start the boiler and bring the system to working temperature, stop the pump, and repeat air bleeding procedure.
- Allow the system to cool and restore water pressure to 1÷1.3 bars.



WARNING

The low water safety pressure switch will not electrically enable the burner ignition when water pressure is below 0.4-0.6 bar.

The CH system water pressure must not be lower than 1 bar. Otherwise, fill the heating system.

The procedure is to be followed while the system is cold.

Pressure gauge is used to read pressure inside the heating circuit.



WARNING

As for water treating in the domestic heating systems in order to optimise efficiency and safety, ensure a long life, trouble-free operation of auxiliary equipment, minimise power consumption, thereby integrating the standards and rules in force in the country of installation, it is recommended to use specific products suitable for multi-metal heating systems.

3.15 Starting up the boiler

3.15.1 Preliminary checks

Before starting the boiler, check that:

- The flue gas venting duct and the relevant terminal are installed in conformity with the instructions: with the boiler operating, there must be no leakage of combustion by-products from any of the gaskets.
- The supply power to the boiler must be 230 V ~ 50 Hz.
- the heating system is correctly filled with water (pressure gauge reading $1 \div 1.3$ bar).
- Any shut-off cocks in the system pipes are open.
- the mains gas type is correct for the boiler calibration: convert the boiler to the available gas if necessary (see *Adaptation to other gas types and burner adjustment* on page 62). This operation is to be exclusively carried out by qualified personnel.
- The gas supply cock is open.
- There are no fuel gas leaks.
- The main switch installed adjacent to the boiler is turned on.
- The 3-bar safety valve is not stuck.
- There are no water leaks.
- The condensate trap installed on the boiler is discharging condensate correctly and is not stuck.

3.15.2 Switching on and switching off

To switch the boiler on and off, refer to the **"Instructions for the User"** (see *Instructions for the user* on page 8).

3.16 Available head

The boiler is equipped with a high-efficiency circulation pump with variable speed.

Circulation pump speed is automatically managed by the electronics, based on the settings of "super technical" parameters of the boiler.

It is possible to choose between two pump working modes:

1 1 "Constant ΔT " operation

In the constant ΔT operating mode, circulation pump speed changes automatically to keep system delivery and return ΔT fixed at a value set in the boiler "super technical" parameters.

2 2 "Fixed speed" operation

In the fixed speed operating mode, circulation pump speed remains constant at the value set in the boiler "super technical" parameters.

In DHW mode circulation pump works at a fixed speed, set via the relevant "super technical" parameters of the boiler.



WARNING

Circulation pump is set to constant ΔT operating mode during production.

For a correct operation of the boiler, it is recommended not to change factory setting.

Should it be necessary to change circulation pump settings, contact a Service Centre.

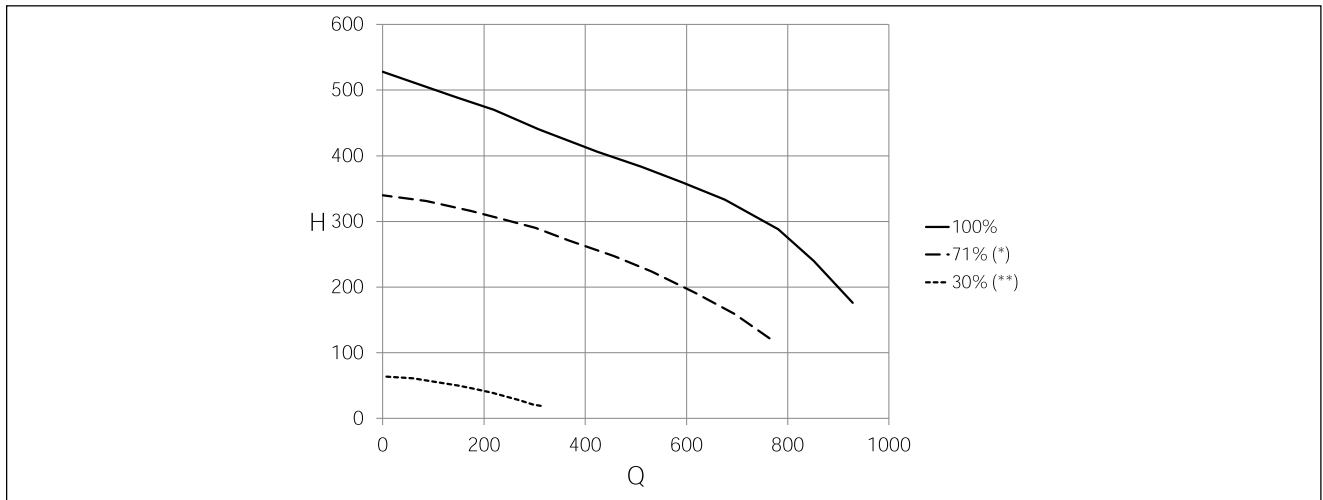

Fig. 20 Available head KC-KR-KRB 12

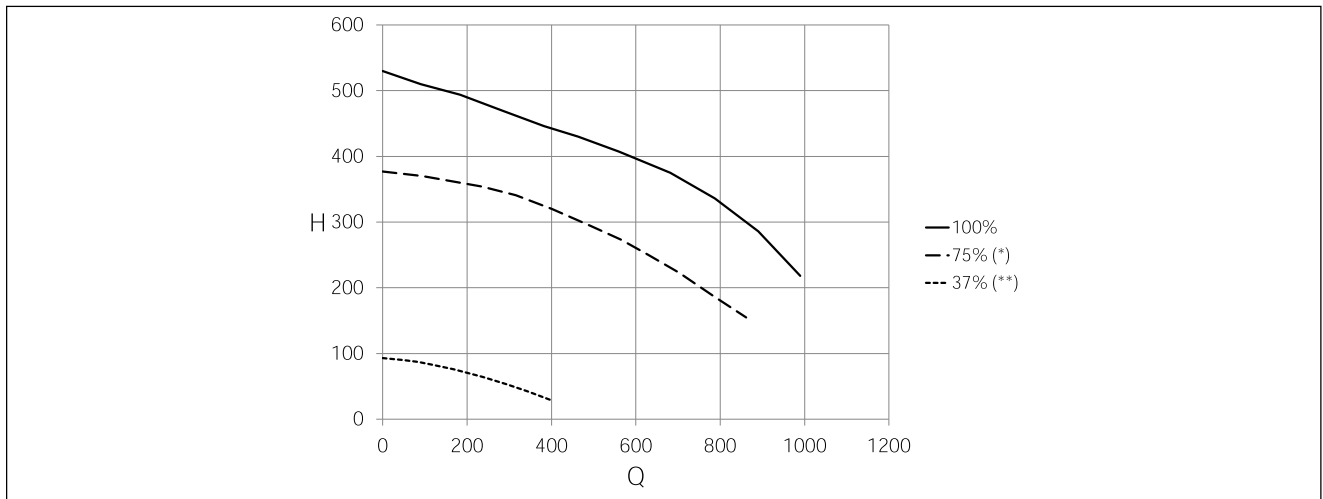

Fig. 21 Available head KC-KR-KRB 24

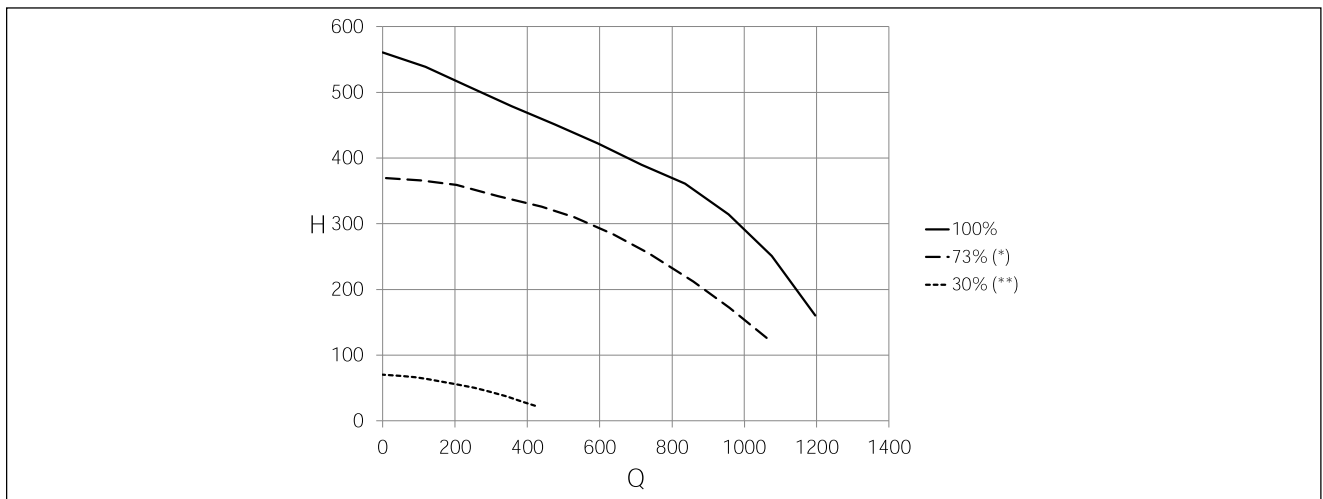

Fig. 22 Available head KC-KR-KRB 28

Q.....Flow rate (l/h)

H.....Available head (mbar)

(*) Minimum curve that can be used in systems without hydraulic separator

(**) Minimum curve that can be used in systems with hydraulic separator

3.17 Wiring diagrams

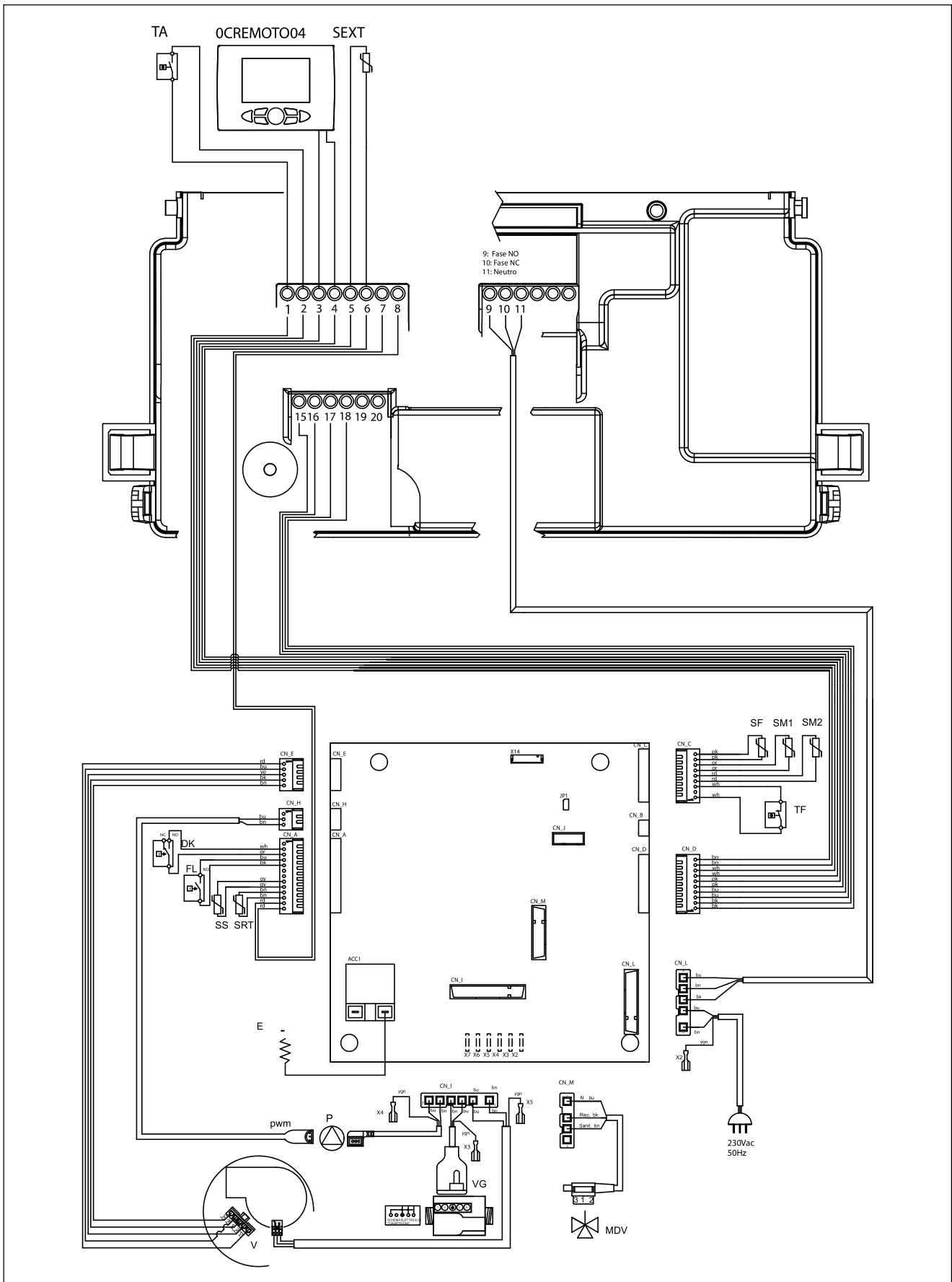

Fig. 23 Wiring diagram KC

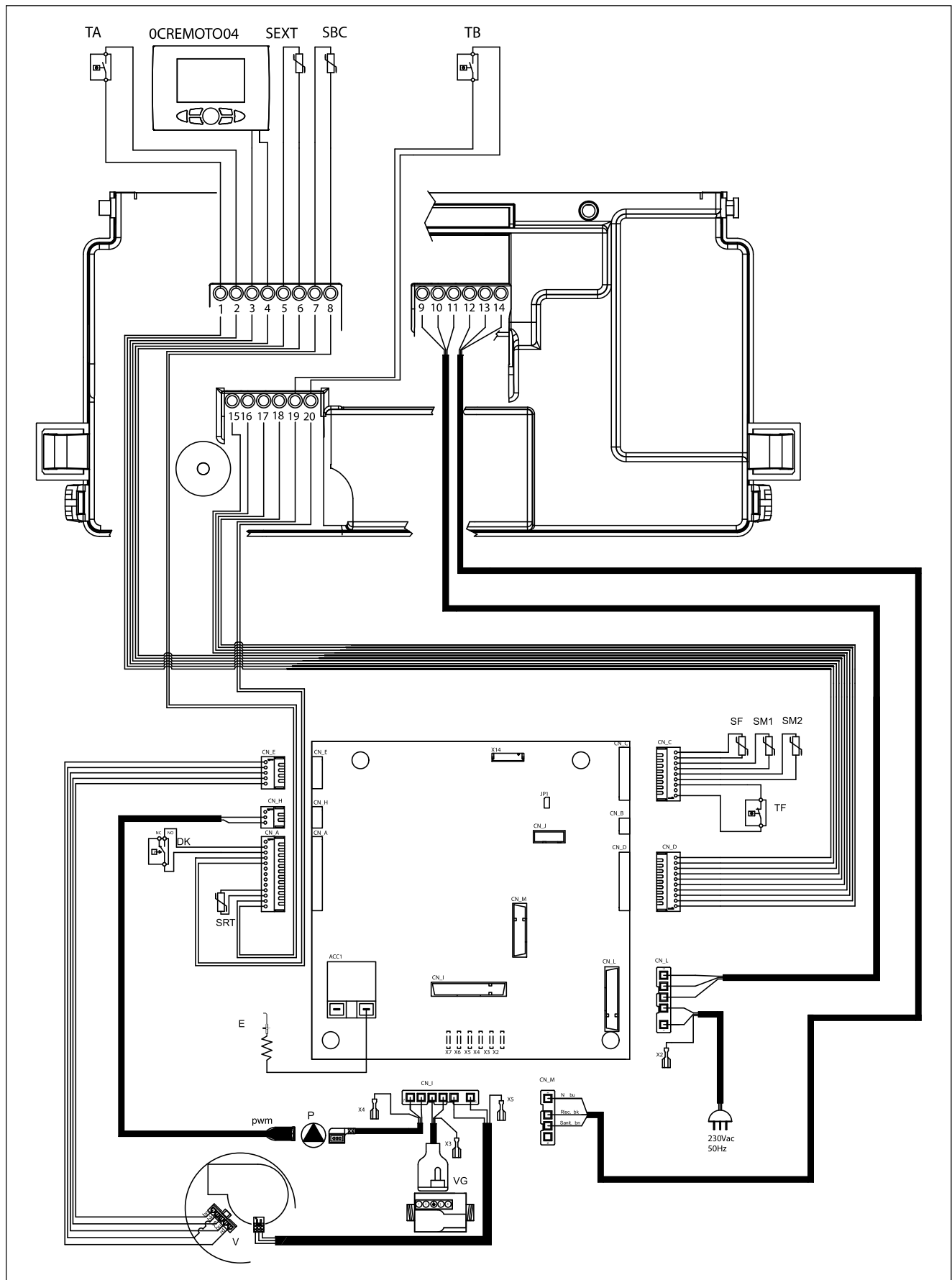

Fig. 24 Wiring diagram KR

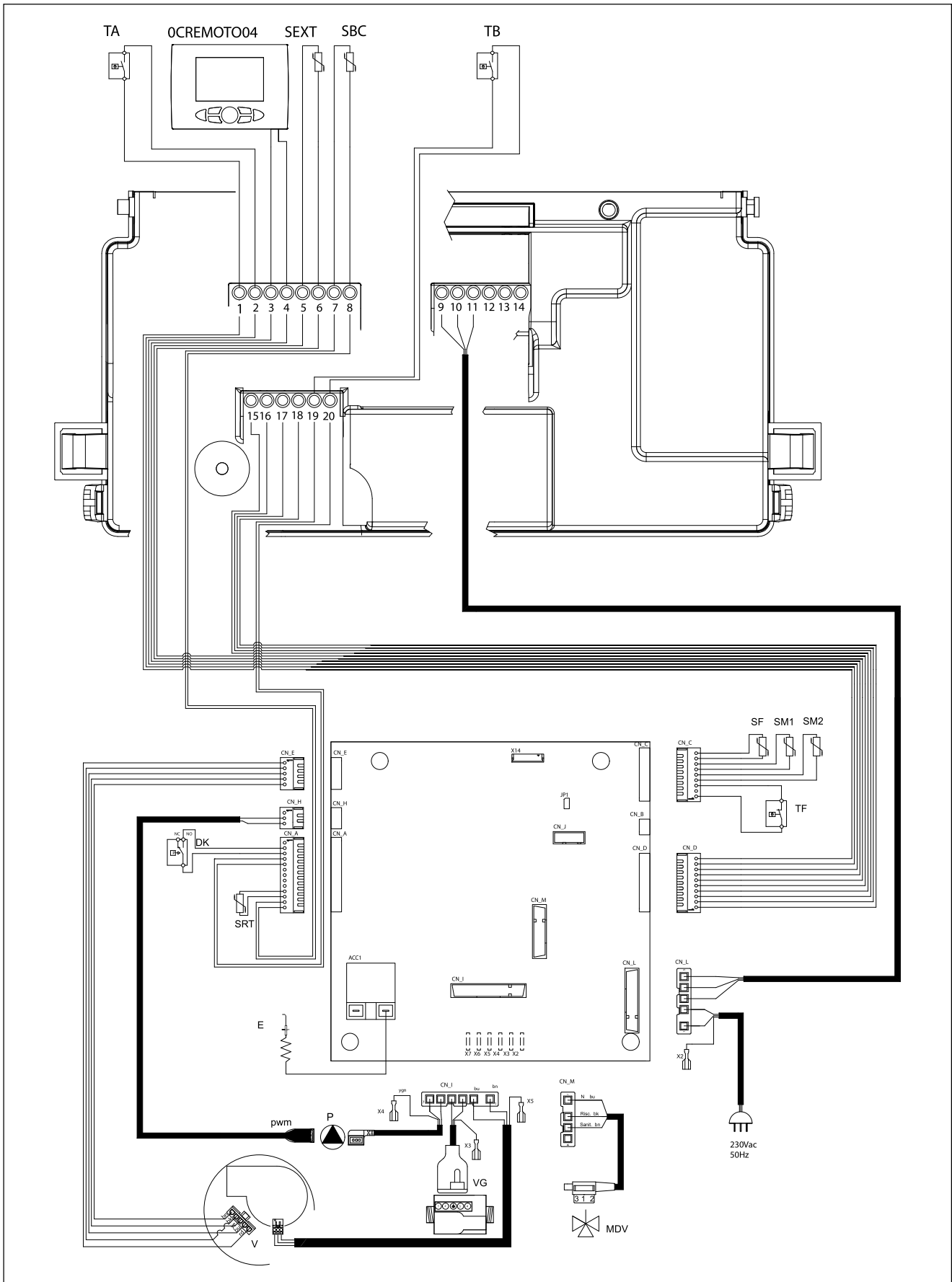

Fig. 25 Wiring diagram KRB

Internal connections

- DK:**..... low water pressure switch
- FL:**..... flow switch
- SS:**..... DHW NTC 'OUT' probe 0k Ohm a 25°C B=2435
- SRT:**..... Return NTC temperature probe 10k Ohm a 25°C B=2435
- SM1-SM2:**..... CH NTC temperature probe 10k Ohm a 25°C B=2435
- SF:**..... flue gas NTC probe 10k Ohm a 25°C B=2435
- TF:**..... flue gas thermostat
- VG:**..... gas valve
- P:**..... boiler pump
- PWM:**..... PMW signal cable for circulation pump
- MDV:**..... electric deviating valve
- E:**..... ignition/flame detection electrode
- V:**..... brushless fan
- CN_A-CN_M:**..... Load/signal connectors
- X2-X7:**..... ground connectors

Connections performed by the installer

- 1-2:**..... room thermostat (TA)
- 3-4:**..... Remote Control (OCREMOTO04)
- 5-6:**..... NTC external probe 10k Ohm at 25 °C B=3977 (SEXT)
- 7-8:**..... boiler water heater probe (SBC, KR/KRB only)
- 9-10-11:**..... Relay which can be freely programmed (230 Vac 5A cosφ=1)
 - 9:**..... phase (NO)
 - 10:**..... phase (NC)
 - 11:**..... neutral (COMMON)
- 12-13-14:**..... 3-way deviating valve (KR only)
 - 12:**..... DHW (neutral, NC)
 - 13:**..... heating (neutral, NO)
 - 14:**..... phase (COMMON)
- 15-16:**..... not used
- 17-18:**..... not used
- 19-20:**..... water heater thermostat (TB)

3.17.1 Relationship between temperature and nominal resistance of all NTC probes

T (°C)	0	2	4	6	8
0	27203	24979	22959	21122	19451
10	17928	16539	15271	14113	13054
20	12084	11196	10382	9634	8948
30	8317	7736	7202	6709	6254
40	5835	5448	5090	4758	4452
50	4168	3904	3660	3433	3222
60	3026	2844	2674	2516	2369
70	2232	2104	1984	1872	1767
80	1670	1578	1492	1412	1336
90	1266	1199	1137	1079	1023

Tab. 20 Relationship between "Temperature and Nominal resistance" for temperature probes

3.18 Adaptation to other gas types and burner adjustment



WARNING

This boiler is built to run on the type of gas specified on the packaging and on the boiler rating plate.

Any later transformation is to be exclusively carried out by qualified personnel, using manufacturer designed accessories and following the procedure and adjustment instructions for an accurate boiler setting-up.

- Disconnect the boiler from the electric power supply.
- Remove boiler outer front panel.
- Loosen the three screws securing combustion chamber front panel to frame, then remove panel.
- Loosen the screw securing intake pipe to mixer, and remove pipe (see Fig. 26 Intake pipe).
- Disconnect the gas pipe from the mixer (see Fig. 26 Intake pipe).
- Loosen the three socket head screws, and remove the mixer (see Fig. 27 Mixer).
- Loosen the two retaining screws, and slide out mixer plastic body (see Fig. 28 Mixer plastic body).
- Using a 6 mm Allen wrench, loosen the two mixer nozzles (see Fig. 28 Mixer plastic body).
- Install the nozzles corresponding to the new gas as specified in Tab. 23 Diameter of nozzles - diaphragms (mm), taking care to drive them fully home, without tightening.



WARNING

In case the nozzle idles when reaching the bottom of the nozzle threaded seat, it means that the thread is damaged and perfect sealing is not ensured. The whole mixer shall be replaced.

- To refit the plastic body (Venturi), insert it inside mixer and secure it in place with the retaining screws. Take care not to damage the O-rings assembled on plastic body ends (see Fig. 28 Mixer plastic body) and to respect the assembling direction (see Fig. 29 Assembling direction).
- Refit the reassembled mixer onto the fan with the socket head screws, making sure to insert the O-ring between mixer and fan (see Fig. 28 Mixer plastic body).
- Reconnect boiler to electric power supply, and open the gas cock.
- Edit value for parameter **P0-TSP0** depending on boiler power (see par. *Edit parameter P0-TSP0* on page 63).
- Adjust the gas valve (see par. *Gas valve setting* on page 64).

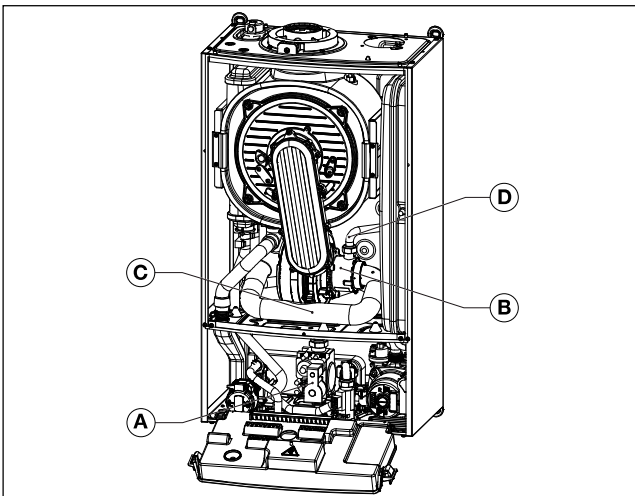

Fig. 26 Intake pipe

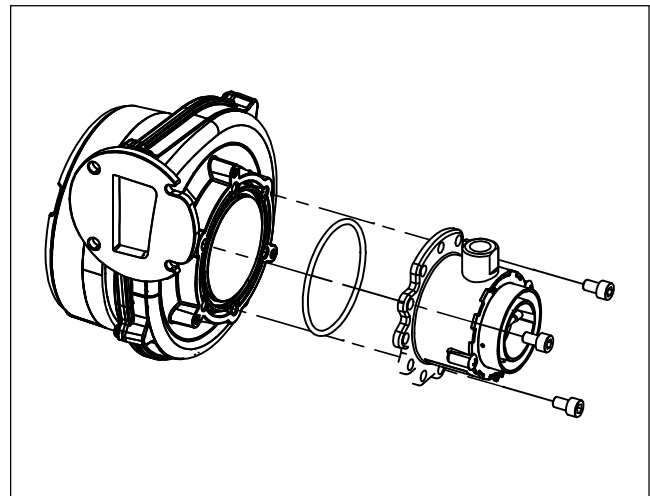

Fig. 27 Mixer

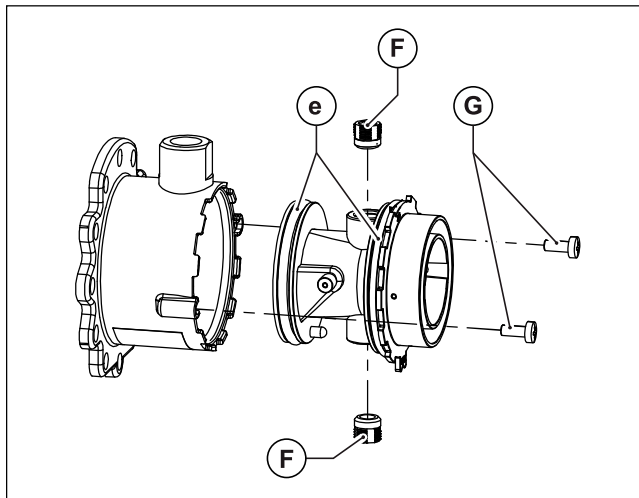

Fig. 28 Mixer plastic body

- A. Gas valve
- B. Mixer
- C. Air intake
- D. Gas pipe
- E. O-ring

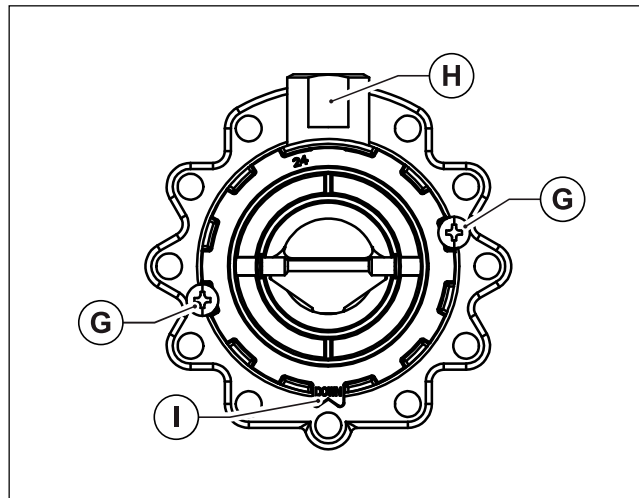

Fig. 29 Assembling direction

- F. Nozzles
- G. Venturi to mixer retaining screws
- H. Gas fitting
- I. Direction tab

3.18.1 Edit parameter P0-TSP0

The boiler operation is controlled by several parameters.

To modify parameters press buttons **Reset** and **- CH** together for 3 seconds.

Scroll through the parameters by pressing **CH +/-** buttons.

As soon as you reach the one to be modified, press **ok**.

The  symbol turns on to indicate that you can edit the parameter value.

The parameter value can be edited using **CH +/-** buttons.

To confirm modification press **Ok**.

To exit the parameter editing mode press button **Reset**.

Boiler settings	Parameter P0-TSP0 value
12 kW Natural gas	0
12 kW Propane	5
24 kW Methane	1
24 kW Propane	3
28 kW Methane	2
28 kW Propane	4

Tab. 21 P0-TSP0 parameter values

3.18.2 Gas valve setting

Maximum heating output adjustment

- Make sure that the ambient thermostat (optional), if fitted, is set to **ON**.
- Select boiler operating mode "CH ONLY" by pressing the "Operating mode" button on the control panel until symbol  is shown.
- Start the "flue chimney" function (see *Flue cleaning function* on page 45). The boiler starts operating at maximum heat output.
- If a gas switching has been made, access the programming page and set the parameter **P0** based on the power and on the gas, as specified in Tab. 21 P0-TSP0 parameter values.
- Check that **P4-P5-P6-P7-P8-P9** parameter values correspond to those specified in Tab. 16 Limits to be set for TSP parameters and default values in relation to boiler type (TSP0) - I.
- Set flue gas CO2 content by turning the ratio adjuster **B** (see Fig. 30 Adjusting CO2 value) and ensure that reading falls within the limits of Tab. 22 Flue CO2 content. Let boiler flue cleaning function on and continue with the next point "Minimum heating output adjustment".

Minimum heating output adjustment

- Set boiler min. output operation by keeping **CH** - button pressed until the value corresponding to fan min. speed for the output and boiler gas is displayed, according to Tab. 16 Limits to be set for TSP parameters and default values in relation to boiler type (TSP0) - I.
- Boiler switches to min. output operation.
- Set flue gas CO2 content by turning the offset control **C** (see Fig. 30 Adjusting CO2 value) and ensure that reading falls within the limits of Tab. 22 Flue CO2 content.
- To exit the flue cleaning mode, press "Reset".

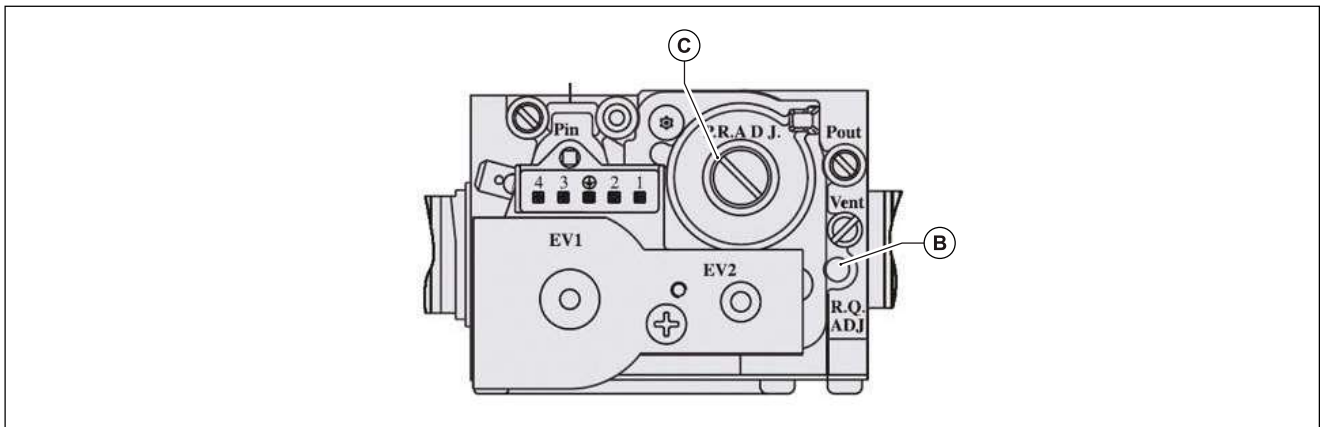

Fig. 30 Adjusting CO2 value

Fuel	CO2 value (%)
12 kW Natural gas	9.0 - 9.3
12 kW Propane	10.0 - 10.3
24 kW Methane	9.0 - 9.3
24 kW Propane	10.0 - 10.0
28 kW Methane	9.0 - 9.3
28 kW Propane	10.0 - 10.3

Tab. 22 Flue CO2 content

Model	Natural gas	Propane
12 kW	3.05	2.50
24 kW	3.70	3.00
28 kW	4.00	3.30

Tab. 23 Diameter of nozzles - diaphragms (mm)

4. Testing the boiler

4.1 Preliminary checks

Before testing the boiler, it is recommended to check the following:

- the flue gas venting duct and the relative terminal are installed in conformity with the instructions: **there must be no leakage of combustion by-products from any of the gaskets.**
- the supply power to the boiler must be 230 V ~ 50 Hz;
- the system is correctly filled with water (pressure gauge reading 1 to 1.3 bar);
- any shut-off cocks in the system pipes are open;
- the mains gas type is correct for the boiler calibration: convert the boiler to the available gas when necessary; this operation must only be performed by qualified technical personnel;
- the gas supply cock is open;
- **there are no fuel gas leaks;**
- the main switch installed ahead of the boiler is turned on;
- the 3-bar safety valve is not stuck;
- there are no water leaks;
- the condensate trap installed on the boiler is discharging condensate correctly and is not stuck.



WARNING

Should the boiler not be installed in compliance with the prevailing laws and standards, notify the system supervisor and do not test the boiler.

4.2 Switching on and switching off

To switch the boiler on and off, refer to the **“Instructions for the User”**.

5. Maintenance



WARNING

Any maintenance (and repair) work must only be carried out by qualified personnel.

The user is strongly advised to have the product serviced and repaired by a service centre or qualified personnel. Appropriate boiler maintenance ensures efficient operation, environment preservation, and safety for people, animals and objects.

The boiler must be serviced at least once every year.



WARNING

Disconnect electric power supply before starting any maintenance procedure, involving replacement of components and/or cleaning inside parts of boiler.

5.1 Maintenance schedule

Maintenance operations include check and cleaning procedures. In particular:

Inspections and checks

- Check general integrity of the boiler.
- Check boiler and network gas supply for leakage.
- Check gas supply pressure to boiler.
- Check boiler ignition sequence.
- Check the condition and seal integrity of the flue gas venting ducts.
- Check integrity of safety devices of the boiler in general.
- Check for water leaks and oxidised areas on the boiler's couplings.
- Check efficiency of the system safety valve.
- Check expansion vessel filling pressure.
- Check water pressure switch efficiency.
- Check boiler combustion parameters by flue gas analysis
- Check the state of combustion fan.
- Check correct draining of condensate from the condensate trap installed on the boiler.

The following cleaning is to be done

- Clean the general interior of the boiler.
- Clean the gas nozzles.
- Clean the air intake and flue gas venting circuits.
- Clean the heat exchanger.
- clean the condensate trap and discharge ducts.

When checking the boiler for the very first time, also verify:

- Boiler room suitability.
- Diameter and length of flue gas system ducts.
- Boiler installation in accordance to this "Installation use and maintenance" manual instructions.



WARNING

Should the boiler not operate correctly, while not posing danger to people, animals or property, notify the system supervisor both verbally and in writing.

5.2 Combustion analysis

The combustion parameters of the boiler, which have to be checked in order to determine efficiency and emissions, must be measured in compliance with applicable legislation and standards.

6. Decommissioning, disassembly and disposal



Warning

If you decide to definitively decommission the boiler, have decommissioning, disassembly and disposal procedures carried out by qualified personnel, only.

The user is not authorised to carry out such operations.

Decommissioning, disassembly and disposal operations must be performed with boiler cold and disconnected from gas and power mains.

The materials the boiler is made of can all be recycled.

Once disassembled, boiler must be disposed of in accordance with the national prevailing regulations.

7. Malfunctions, possible causes and solutions

7.1 Troubleshooting

BOILER STATUS	MALFUNCTION	PROBABLE CAUSE	USER'S TASKS	QUALIFIED PERSONNEL'S TASKS	
E01*	Burner does not ignite	Gas supply failure.	Check gas supply. Check gas supply cock or gas network safety valve intervention.		
		Gas valve is disconnected.	Contact qualified personnel	Reconnect it.	
		Gas valve is faulty.	Contact qualified personnel	Replace it.	
		The board is faulty.	Contact qualified personnel	Replace it.	
	Burner does not ignite: no spark	Ignition relay is faulty.	Contact qualified personnel	Replace the electrode.	
		Ignition transformer is faulty	Contact qualified personnel	Replace the ignition transformer.	
		Electronic board does not ignite. It is faulty.	Contact qualified personnel	Replace electronic board.	
	Burner ignites for a few seconds and goes off.	Electronic board does not detect flame: inverted phase and neutral.	Contact qualified personnel	Verify correct neutral and phase connection.	
		Detection electrode cable is interrupted.	Contact qualified personnel	Reconnect or replace wire.	
		Detection electrode is faulty.	Contact qualified personnel	Replace the electrode.	
		Electronic board does not detect flame: it is faulty.	Contact qualified personnel	Replace electronic board.	
		Ignition heat input setting is too low.	Contact qualified personnel	Increase it.	
Minimum heat input is not set correctly.		Contact qualified personnel	Check burner setting.		
E02*	Flow temperature exceeded the max. allowed value.	Circulation pump is faulty.	Contact qualified personnel	Replace it.	
		Circulation pump is seized.	Contact qualified personnel	Check pump electrical connection.	
E03*	Flue thermostat triggering.	Poor flue draught.	Contact qualified personnel	Check the chimney and ambient air-intake grilles.	
		Flue vent/air intake duct is obstructed.	Contact qualified personnel	Check for any duct obstruction, and eliminate.	
		Flue gas thermostat is faulty.	Contact qualified personnel	Replace it.	
E04**	CH system water pressure is low.	The system is leaking.	Check system.		
		Pressure transducer is disconnected.	Contact qualified personnel	Reconnect it.	
		Pressure transducer is faulty.	Contact qualified personnel	Replace it.	
E05**	CH probe failure	Flow probe is electrically disconnected.	Contact qualified personnel	Reconnect it.	
		Flow probe faulty.	Contact qualified personnel	Replace it.	

BOILER STATUS	MALFUNCTION	PROBABLE CAUSE	USER'S TASKS	QUALIFIED PERSONNEL'S TASKS
E06**	DHW probe failure (KC only).	DHW probe is electrically disconnected.	Contact qualified personnel	Reconnect it.
		DHW probe faulty.	Contact qualified personnel	Replace it.
E07**	Flue probe failure	Flue probe is electrically disconnected.	Contact qualified personnel	Reconnect it.
		Flue probe is faulty.	Contact qualified personnel	Replace it.
E12**	Water heater probe (KR/KRB with optional external water heater fitted with NTC probe)	Probe is disconnected.	Contact qualified personnel	Reconnect it.
		Probe is faulty.	Contact qualified personnel	Replace it.
E15**	Return probe failure.	Probe is disconnected.	Contact qualified personnel	Reconnect it.
		Probe is faulty.	Contact qualified personnel	Replace it.
E31**	Remote Control connection failure (only shown on Remote Control display).	The Remote Control is not connected to boiler board.	Contact qualified personnel	Reconnect it.
		Remote control faulty.	Contact qualified personnel	Replace it.
		Boiler board is faulty.	Contact qualified personnel	Replace it.
E35**	Safety thermostat protecting the mixed 'zone 2' triggering (with "OKITZONE05" zone kit installed, only)	Mixer valve is faulty.	Contact qualified personnel	Replace it.
		Thermostat is disconnected.	Contact qualified personnel	Reconnect it.
		Thermostat is faulty	Contact qualified personnel	Replace it.
E36**	Flow probe failure on one of the installed zones (with zone kit "OKITZONE05" installed, only).	Probe is disconnected.	Contact qualified personnel	Reconnect it.
		Probe is faulty.	Contact qualified personnel	Replace it.
E40*	Fan failure.	Fan disconnected.	Contact qualified personnel	Reconnect it.
		Fan faulty.	Contact qualified personnel	Replace it.
E41**	Communication error between main board and additional devices (zone boards).	Zone boards are not connected.	Contact qualified personnel	Reconnect them.
		Zone boards are faulty.	Contact qualified personnel	Replace them.
E42	Hydraulic system setting error.	Main PCB parameters are not correct.	Contact qualified personnel	Check P3 parameter value.

BOILER STATUS	MALFUNCTION	PROBABLE CAUSE	USER'S TASKS	QUALIFIED PERSONNEL'S TASKS
E51	Shut-down due to safety circuit hardware fault	Boiler electronic board is faulty.	Contact qualified personnel	Check boiler electronic board.
E52				
E53				
E80*	The ΔT between flow and return is not within the limits.	Flow and/or return probes are faulty.	Contact qualified personnel	Replace them.
		Obstructed bypass pipe	Contact qualified personnel	Remove any obstructions, or replace the pipe.
		The bypass valve is not assembled or wrongly assembled.	Contact qualified personnel	Restore bypass valve correct assembling.
		Heat exchanger primary circuit is obstructed.	Contact qualified personnel	Clean or replace the exchanger.
E86*	Flow temperature increases too quickly.	Pump is seized.	Contact qualified personnel	Unseize the pump.
		Pump is faulty.	Contact qualified personnel	Replace it.
		Air present inside heating system.	Contact qualified personnel	Bleed the air from the boiler by opening the jollies on the exchanger and pump.
E87*	Return temperature increases too quickly.	Circulation of foreign water in boiler.	Contact qualified personnel	Check that there are no other boilers or additional cascading heat sources.
		Air present inside heating system.	Contact qualified personnel	Bleed the air from the boiler by opening the jollies on the exchanger and pump.
E89***	Faulty flue temperature value.	Flue probe on heat exchanger is faulty or damaged.	Contact qualified personnel	Replace it.
E98	The max. number of resets from the boiler interface has been reached.	The user has reached the max. number of resettable errors from boiler.	Press RESET button	
E99	The max. number of resets from the Remote Control has been reached.	The user has reached the max. number of resettable values from the Remote Control.	Press RESET button	

* errors that can be reset by the user by keeping the **RESET** button pressed

** self-resettable errors, they automatically reset as soon as the failure is fixed

*** errors that can be reset only by the Technical Service personnel

If errors **E73**, **E85**, **E90** and **E91** are displayed, please contact a qualified Service Centre.

MANUFACTURER'S COMPLIANCE STATEMENT

Gas Directive 2009/142/EC
Efficiency Requirements Directive 92/42/EC
Electromagnetic Compatibility Directive 2004/108/EC
Low Voltage Directive 2006/95/EC
Ecodesign Directive 2009/125/CE
Energy Labelling Directive 2010/30/CE

FONDITAL S.p.A.
having its registered office in
Via Cerreto 40 - 25079 Vobarno (BS), Italy

STATES

that the products

Delfis KC 12, Delfis KRB 12, Delfis KR 12
Delfis KC 24, Delfis KRB 24, Delfis KR 24
Delfis KC 28, Delfis KRB 28, Delfis KR 28

are manufactured in conformity

1. With the Type described in the CE-Type Examination Certificate and in the CE-Type Examination Certificate **51CM4094/ED**
51CM4095DR/ED

following the provisions of the Directives
Gas Directive 2009/142/EC
Efficiency Requirements Directive 92/42/EC
which satisfy the essential requisites.

2. With the provisions of the **Electromagnetic Compatibility Directive 2004/108/EC.**
3. With the provisions of the **Low Voltage Directive 2006/95/EC.**
4. With the provisions of the **Ecodesign Directive 2009/125/CE.**
5. With the provisions of the **Energy Labelling Directive 2010/30/CE.**

Fondital S.p.A.

For management
Officer i/c Technical Office

Eng. Roberto Cavallini



Vobarno, date of issue or of postal mark

Dichiarazione di conformità caldaie

Delfis KX - Edizione 1 del 18 giugno 2015

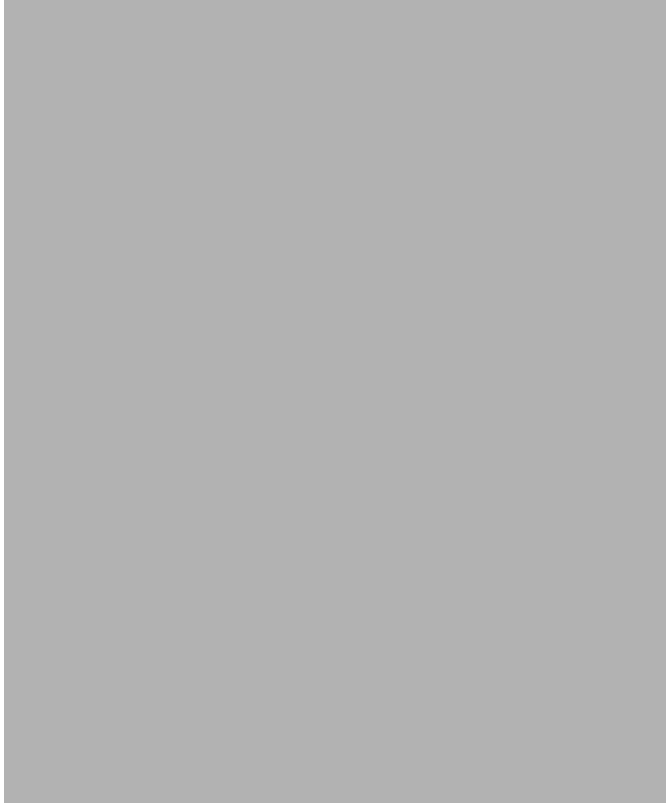

OLIBMEEN22

v Fondital S.p.A.

25079 VOBARNO (Brescia) Italy - Via Cerreto, 40

Tel. +39 0365/878.31

Fax +39 0365/878.304

e mail: info@fondital.it

www.fondital.com

The manufacturer reserves the right to modify his/her products as deemed necessary, without altering the basic characteristics of the products themselves.

Uff. Pubblicità Fondital IST 04 C 429-01 Luglio 2015 (07/2015)